

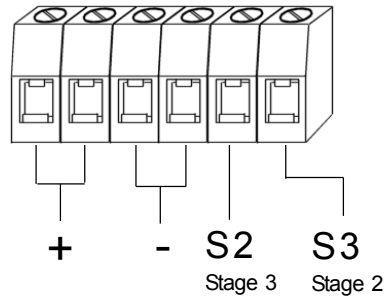

MBL1 - L.E.D Marine grade IP66 & IP67 Beacons & Status Lights

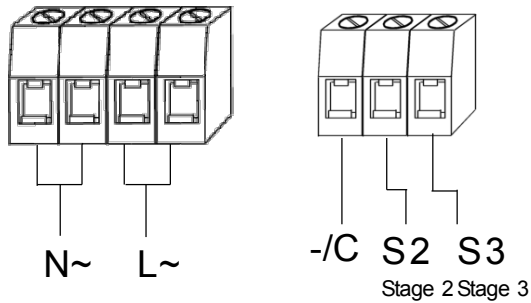

DC units

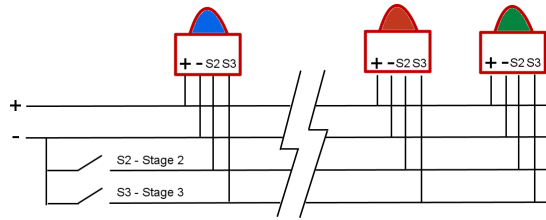

AC units

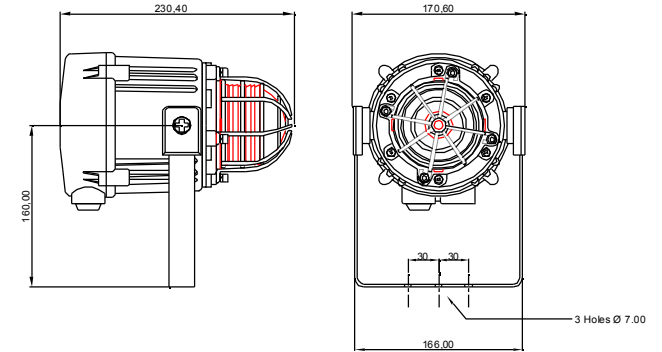
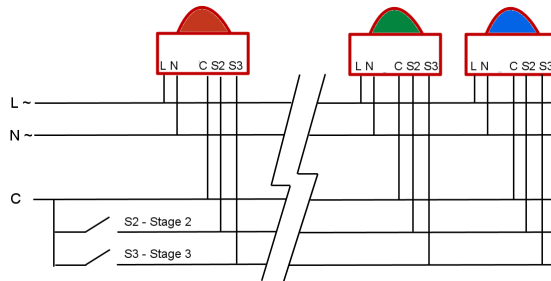

Voltage :	24vdc	48vdc	115vac	230vac	24vac
			50/60Hz	50/60Hz	50/60Hz
Voltage range :	10-50vdc	10-50vdc	+/-10%	+/-10%	+/-10%
Current mA :	400mA	230mA	140mA	70mA	380mA

Stage 1	L.E.D Pattern Description	Stage 2	Stage 3
1	All on	9	8
2	Rotating 3 LED on Fast	7	1
3	Rotating 6 LED on Fast	8	1
4	Rotating 3 LED on Slow	9	1
5	Rotating 6 LED on Slow	6	1
6	Double strike strobe 1Hz	9	1
7	Single strike strobe 2Hz	3	1
8	Double strike strobe 2Hz	3	1
9	Alternate side flash 1:1 2Hz	3	1

Pattern selection pin headers

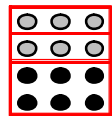

PCB Edge

