

INSTRUCTION & SERVICE MANUAL
MA1 & MA2 M Range Sounders

- IP67/66 & Type 4/4X/13
- -40°C to +66°C (-40°F to +151°F)
- DC: 2.5Kg (5.5lb); AC: 3.0Kg (6.5lb)
- CE, EAC & Russian Maritime Register approved

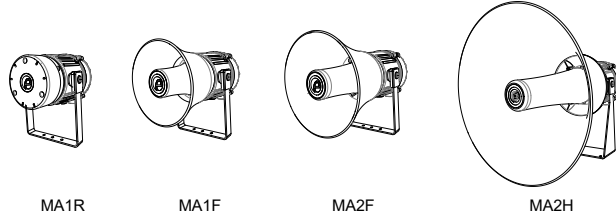

Unit Type Code	Nominal Voltage	Voltage Range	Nominal Current P1 (mA)	Nominal Current P2 (mA)	Nominal Current P3 (mA)	Sound Pressure Level P1, dB(A)			Sound Pressure Level P2, dB(A)			Sound Pressure Level P3, dB(A)			
						Max*	Nom [†]	\bar{x} [‡]	Max*	Nom [†]	\bar{x} [‡]	Max*	Nom [†]	\bar{x} [‡]	
MA1RDC024	12 Vdc / 24 Vdc / 48Vdc	10-60Vdc	280/			113.6	110.7	109.7							
MA1FDC024			224/122			116.6	113.7	112.7							
MA2FDC024				376/391/223 [§]	440/888/453					120.0	116.6	114.7	123.4	120.1	118.0
MA2HDC024			376/391/223	440/888/453 [§]					125.3	122.5	120.1	128.6	125.9	123.1	
MA1RAC230	115 Vac / 230 Vac	100 - 240Vac 50/60Hz	100/64			113.6	110.7	109.7							
MA1FAC230						116.6	113.7	112.7							
MA2FAC230				173/107 [§]	340/212					120.0	116.6	114.7	123.4	120.1	118.0
MA2HAC230			173/107	340/212 [§]					125.3	122.5	120.1	128.6	125.9	123.1	

*Max = Tone 4 / [†]Nom. = Tone 44 / [‡] \bar{x} = Average over 64 tones / [§] Denotes factory P2/P3 setting

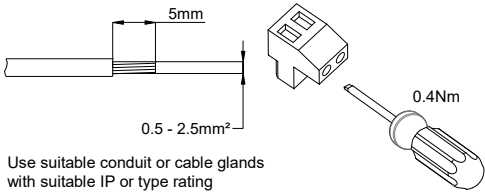

Attention: Installation must be carried out by an electrician in compliance with the latest codes and regulations.
 Attention: L'installation doit être effectuée par un électricien conformément aux derniers codes et réglementations.
 Achtung: Die Installation muss von einem Elektriker gemäß den neuesten Vorschriften und Bestimmungen durchgeführt werden.
 Attenzione: L'installazione deve essere eseguita da un elettricista in conformità con i codici e le normative più recenti.
 Atención: La instalación debe ser realizada por un electricista de acuerdo con los últimos códigos y regulaciones.
 Atenção: A instalação deve ser realizada por um electricista de acordo com os códigos e regulamentos mais recentes.
 Внимание: установка должна выполняться электриком в соответствии с последними нормами и правилами.
 Attention: Disconnect from power source before installation or service to prevent electric shock
 Attention: Débranchez-le de la source d'alimentation avant l'installation ou l'entretien pour éviter tout choc électrique.
 Achtung: Vor Installation oder Wartung von der Stromquelle trennen, um einen Stromschlag zu vermeiden.
 Attenzione: scollegare dall'alimentazione prima dell'installazione o dell'assistenza per evitare scosse elettriche.
 Atención: desconéctelo de la fuente de alimentación antes de la instalación o el servicio para evitar descargas eléctricas.
 Atenção: Desconecte da fonte de alimentação antes da instalação ou serviço para evitar choque elétrico
 Внимание: отключите от источника питания перед установкой или обслуживанием, чтобы предотвратить поражение электрическим током.

AC See D207-06-001

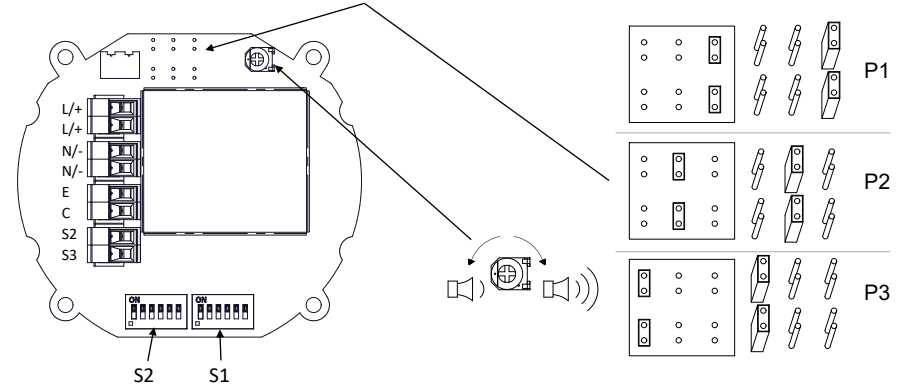

DC See D207-06-005

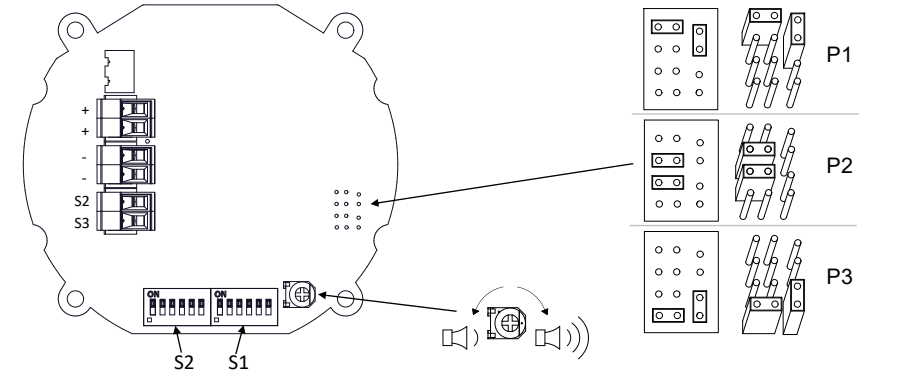

(DC Only, see D207-06-001)

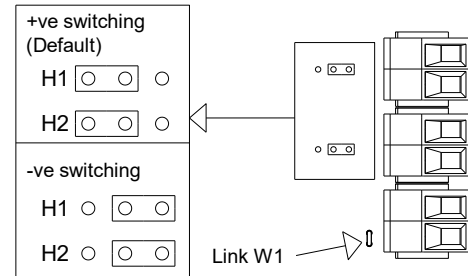

(AC & DC, see D221-95-001)

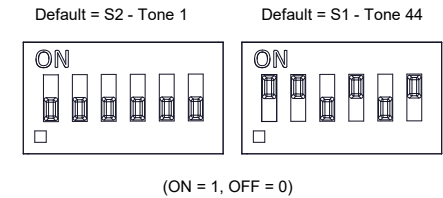

INSTRUCTION & SERVICE MANUAL
 MA1 & MA2 M Range Sounders

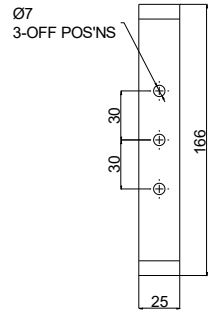
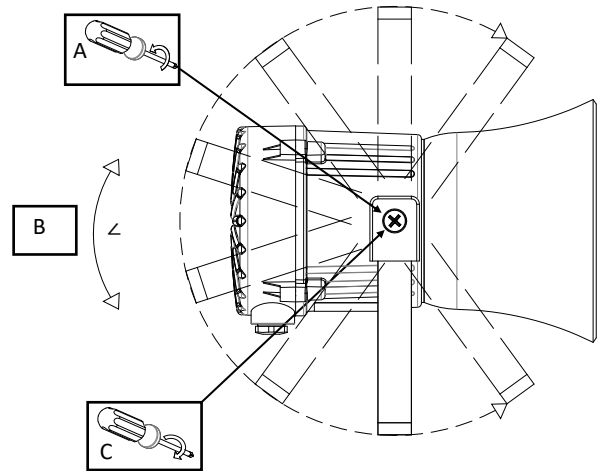

MA1R, MA1F, MA2F

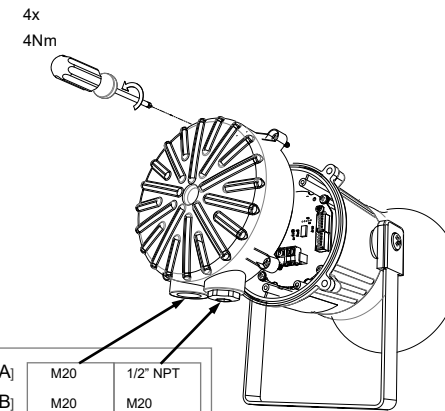

MA[X][F][VOLT][A]	M20	1/2" NPT
MA[X][F][VOLT][B]	M20	M20
MA[X][F][VOLT][C]	1/2" NPT	1/2" NPT

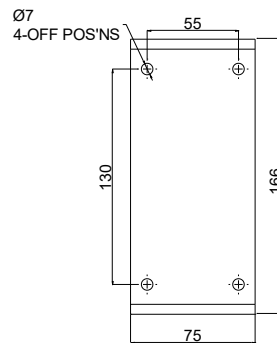
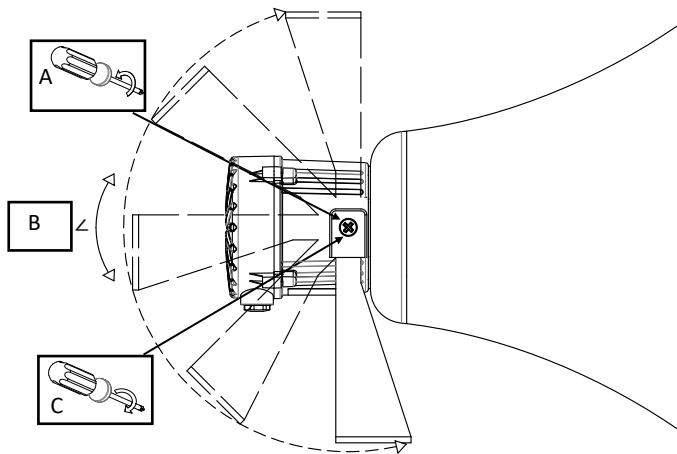

MA2H

1	2	3	4	5	6	7	8	9	10
							ISSUE	MOD No.	REASON - INITIAL - DATE
							A		INTRODUCTION RSR - 05/03/2021

OPTIONAL LINE MONITORING RESISTOR, CUSTOMER SUPPLIED,
RECOMMENDED MINIMUM VALUES:
14V MAX SYSTEM = 120Ω MIN, 2W MIN OR 1KΩ MIN, 0.5W MIN
28V MAX SYSTEM = 470Ω MIN, 2W MIN OR 2.4KΩ MIN, 0.5W MIN

Single Stage Configuration	Config.: 1a	Two Stage Configuration	Config.: 1b	Three/Four Stage Configuration	Config.: 1c
Line Monitoring Set to positive switching (default)		Common Negative Set to positive switching (default)		Common Negative Set to positive switching (default)	
Stage 1: Apply Power to Stage 1 +ve & Stage 1 -ve		Stage 1: Apply Power to Stage 1 +ve & Common -ve Stage 2: Apply Power to Stage 2 +ve & Common -ve		Stage 1: Apply Power to Stage 1 +ve & Common -ve Stage 2: Apply Power to Stage 2 +ve & Common -ve Stage 3: Apply Power to Stage 3 +ve & Common -ve Stage 4: Apply Power to Stage 2 +ve, Stage 3 +ve & Common -ve	

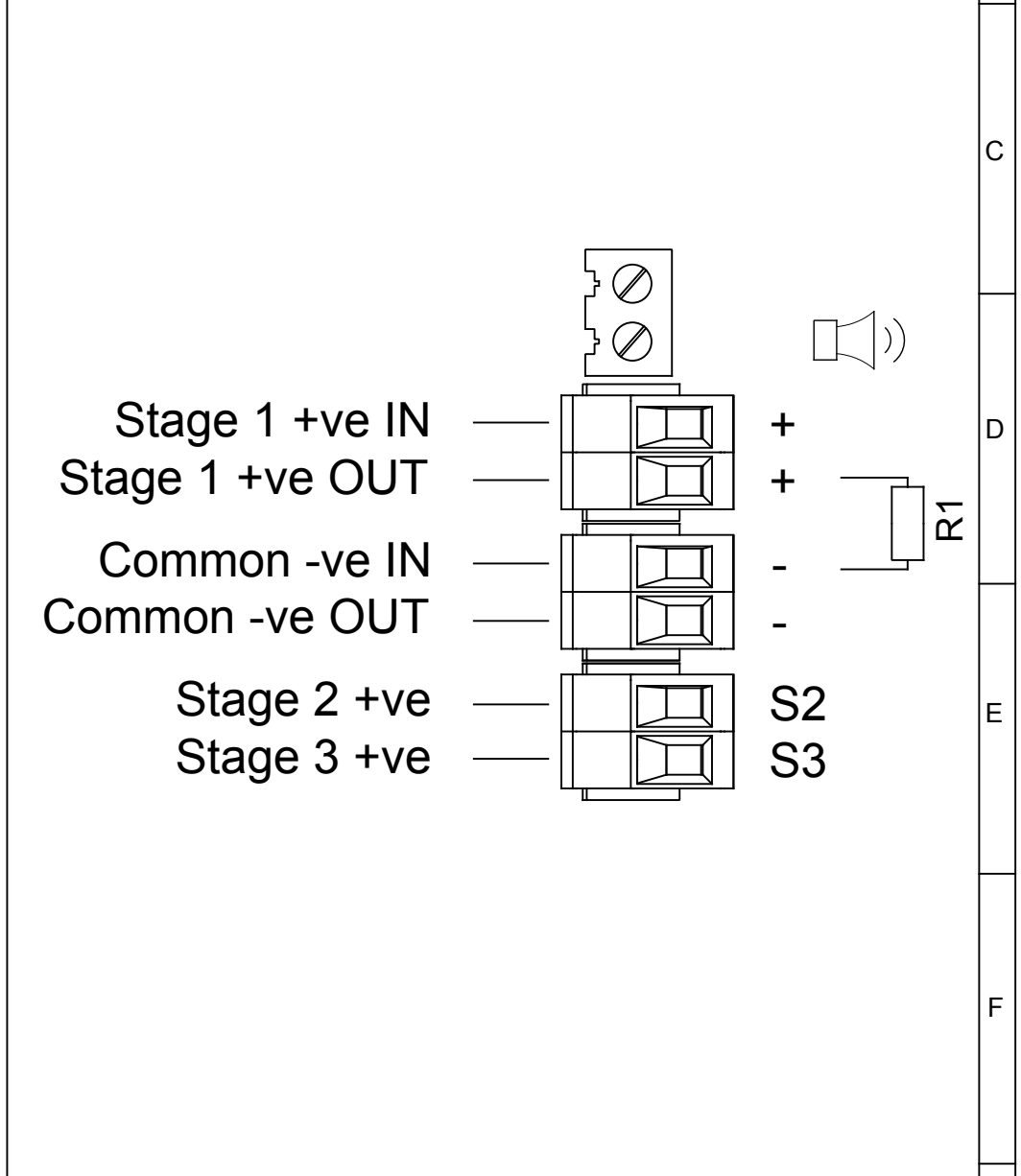
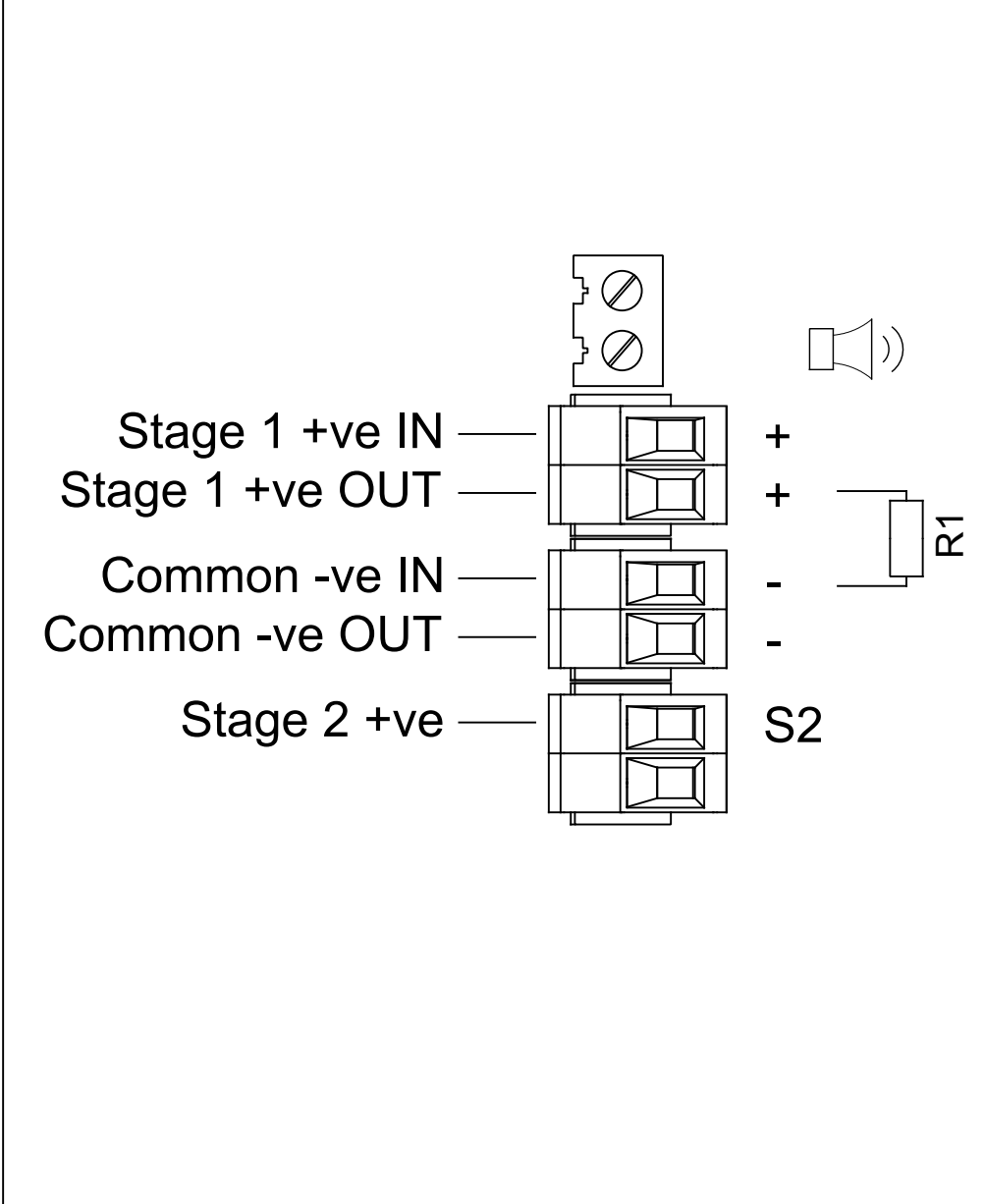
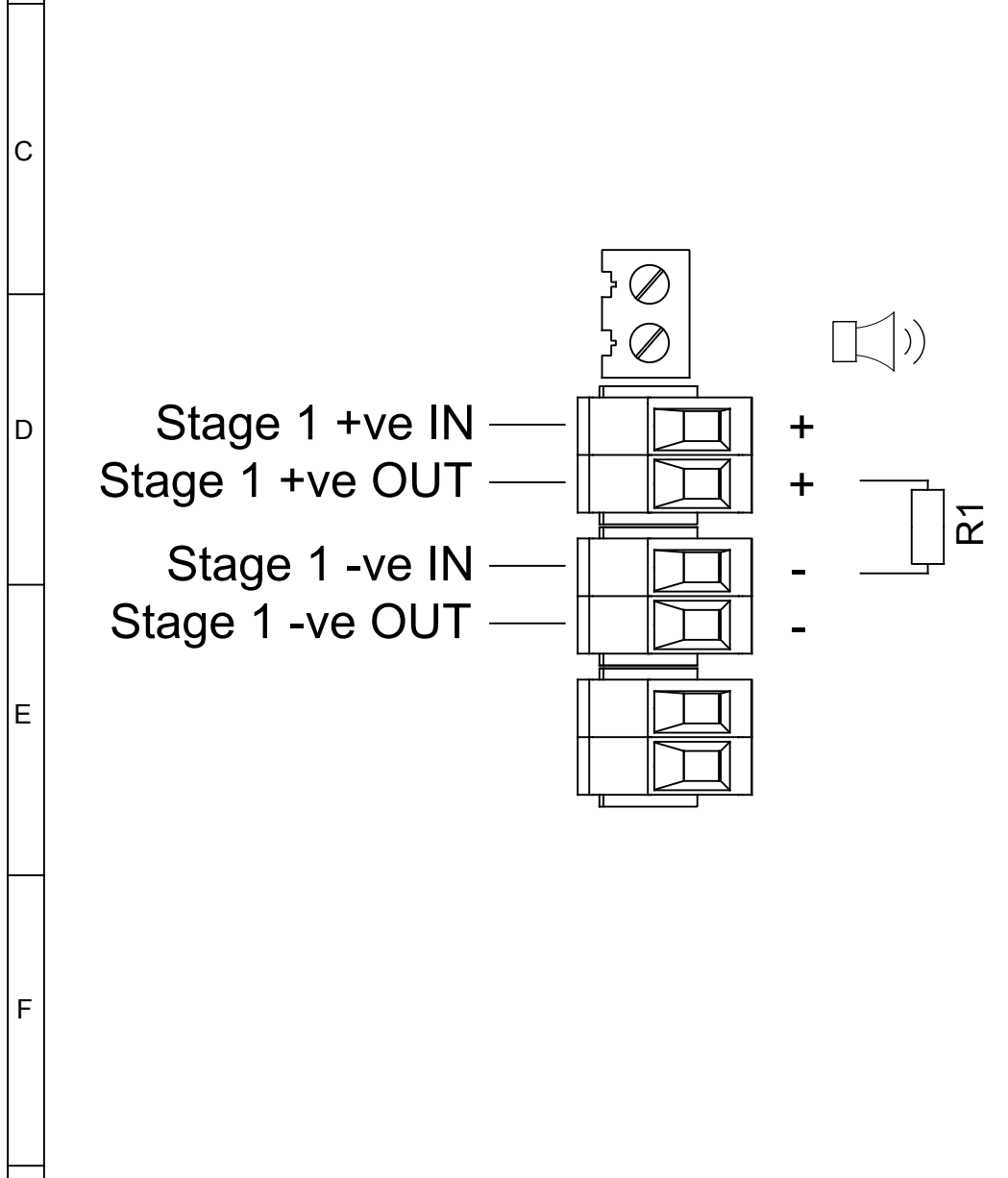

DRAWING TO BS8888:2000 GEOMETRIC TOLERANCES TO ISO1101:1983 LINEAR DIMENSIONAL TOLS ANGULAR DIMENSIONAL TOLS	DRAWN	DATE	SURFACE FINISH	WEIGHT (Kg)	THIS DRAWING AND ANY INFORMATION OR DESCRIPTIVE MATTER THEREIN IS COMMUNICATED IN CONFIDENCE AND IS THE COPYRIGHT PROPERTY OF EUROPEAN SAFETY SYSTEMS LTD. NEITHER THE WHOLE OR ANY EXTRACT MAY BE DISCLOSED, LOANED, COPIED OR USED FOR MANUFACTURING OR TENDERING PURPOSES WITHOUT THEIR WRITTEN CONSENT.		ALL DIMENSIONS IN MM IF IN DOUBT, ASK - DO NOT SCALE			A3
	R.S.RAIT	05/03/2021								
	CHECKED	DATE	ALTERNATIVE MATERIAL							
	B.ISARD	05/03/2021								
STANDARDS	APPROVED	DATE			© EUROPEAN SAFETY SYSTEMS LTD. AS PER LATEST DATE OF ISSUE SHOWN ABOVE	TITLE MA1R, MA1F, MA2F & MA2H DC SOUNDER WIRING DIAGRAMS				
M RANGE	R.N.POTTS	05/03/2021	SCALE	SHEET		DRAWING NUMBER	NTS	1 OF 3	D207-06-001	

1	2	3	4	5	6	7	8	9	10	
								ISSUE	MOD No.	REASON - INITIAL - DATE
								A		INTRODUCTION RSR - 05/03/2021

OPTIONAL LINE MONITORING RESISTOR, CUSTOMER SUPPLIED,
RECOMMENDED MINIMUM VALUES:
14V MAX SYSTEM = 120Ω MIN, 2W MIN OR 1KΩ MIN, 0.5W MIN
28V MAX SYSTEM = 470Ω MIN, 2W MIN OR 2.4KΩ MIN, 0.5W MIN

SWITCHES FOR STAGE OPERATION
CUSTOMER SUPPLIED

Three/Four Stages. Voltage Free 2nd, 3rd & 4th Stage Activation Configuration	Config.: 2	Two Stage Configuration	Config.: 3
---	------------	-------------------------	------------

Stage 1: Apply Power to Stage 1 +ve & Common -ve Stage 2: Apply Power to Stage 1 +ve & Common -ve & connect Stage 2 -ve to Common -ve Stage 3: Apply Power to Stage 1 +ve & Common -ve & connect Stage 3 -ve to Common -ve Stage 4: Apply Power to Stage 1 +ve & Common -ve & connect Stage 2 -ve & Stage 3 -ve to Common -ve	Stage 1: Apply Power to Stage 1 +ve & Stage 1 -ve Stage 2: Apply Power to Stage 1 +ve & Stage 1 -ve & connect Stage 2 -ve to Stage 1 -ve
---	---

Stage 1: Apply Power to Stage 1 +ve & Common -ve
Stage 2: Apply Power to Stage 1 +ve & Common -ve & connect Stage 2 -ve to Common -ve
Stage 3: Apply Power to Stage 1 +ve & Common -ve & connect Stage 3 -ve to Common -ve
Stage 4: Apply Power to Stage 1 +ve & Common -ve
& connect Stage 2 -ve & Stage 3 -ve to Common -ve

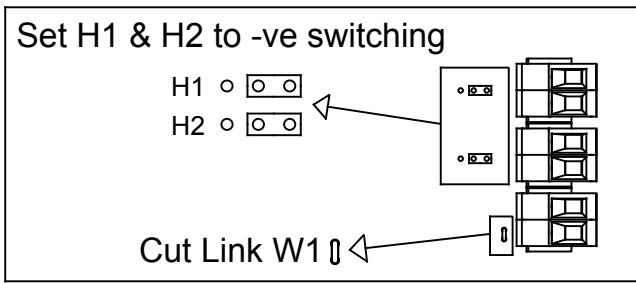
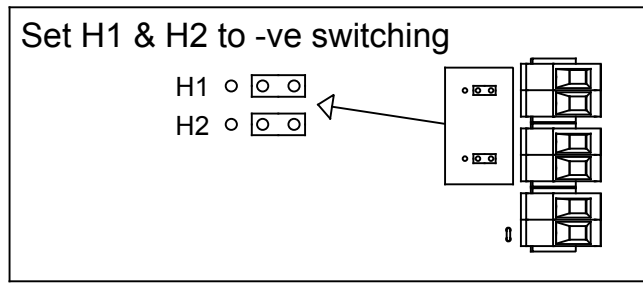
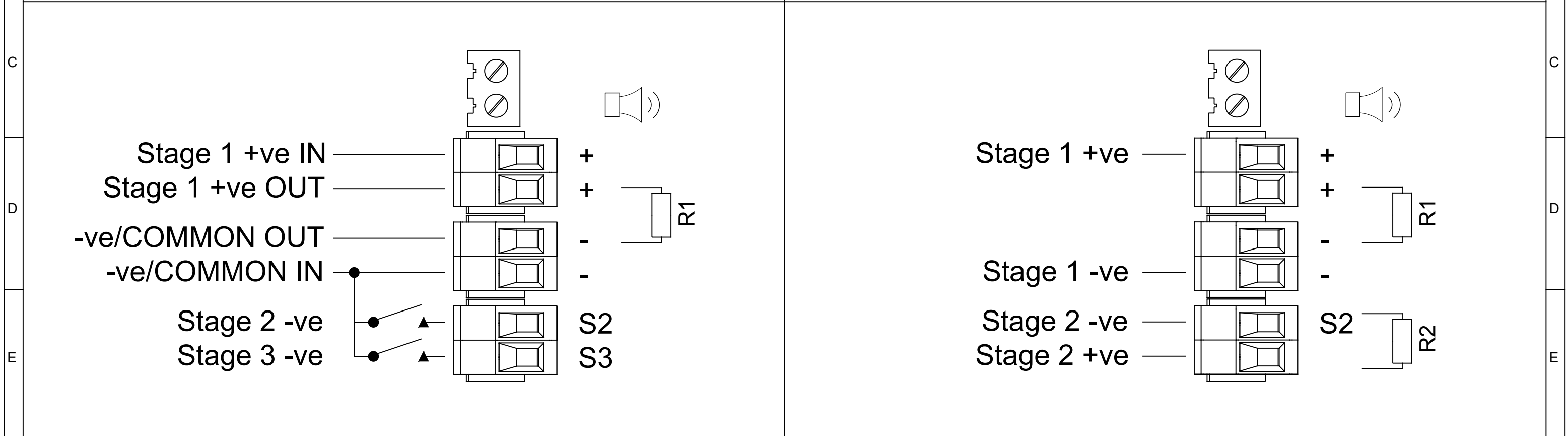

DRAWING TO BS8888:2000 GEOMETRIC TOLERANCES TO ISO1101:1983 LINEAR DIMENSIONAL TOLS ANGULAR DIMENSIONAL TOLS	DRAWN	DATE	SURFACE FINISH	WEIGHT (Kg)	THIS DRAWING AND ANY INFORMATION OR DESCRIPTIVE MATTER THEREIN IS COMMUNICATED IN CONFIDENCE AND IS THE COPYRIGHT PROPERTY OF EUROPEAN SAFETY SYSTEMS LTD. NEITHER THE WHOLE OR ANY EXTRACT MAY BE DISCLOSED, LOANED, COPIED OR USED FOR MANUFACTURING OR TENDERING PURPOSES WITHOUT THEIR WRITTEN CONSENT.		ALL DIMENSIONS IN MM IF IN DOUBT, ASK - DO NOT SCALE			A3
	R.S.RAIT	05/03/2021					MATERIAL			
	CHECKED	DATE	ALTERNATIVE MATERIAL				TITLE MA1R, MA1F, MA2F & MA2H DC SOUNDER WIRING DIAGRAMS			
	B.ISARD	05/03/2021					SCALE	SHEET	DRAWING NUMBER	
STANDARDS	APPROVED	DATE			NTS	2 OF 3	D207-06-001			
M RANGE	R.N.POTTS	05/03/2021								

© EUROPEAN SAFETY SYSTEMS LTD.
AS PER LATEST DATE OF ISSUE SHOWN ABOVE

1	2	3	4	5	6	7	8	9	10
							ISSUE	MOD No.	REASON - INITIAL - DATE
							A		INTRODUCTION RSR - 05/03/2021

OPTIONAL LINE MONITORING RESISTOR, CUSTOMER SUPPLIED,
RECOMMENDED MINIMUM VALUES:
14V MAX SYSTEM = 120Ω MIN, 2W MIN OR 1KΩ MIN, 0.5W MIN
28V MAX SYSTEM = 470Ω MIN, 2W MIN OR 2.4KΩ MIN, 0.5W MIN

SWITCHES FOR STAGE OPERATION
CUSTOMER SUPPLIED

Two Stage Configuration	Config.: 4	Two/Three Stage Voltage Free Activation Configuration	Config.: 5	Three/Four Stage Configuration	Config.: 6
Line Stage Monitoring (Use suitable monitoring relays/modules) Not to be used for reverse polarity monitoring				Independent Stage Input Line Stage Monitoring (Use suitable monitoring relays/modules) Set to positive switching (Default)	
Stage 1: Apply Power to Stage 1 +ve & Stage 1 -ve Stage 2: Apply Power to Stage 2 +ve & Stage 2 -ve		Power: +ve & -ve Stage 1: Connect Stage 1 -ve to Common -ve Stage 2: Cconnect Stage 2 -ve to Common -ve Stage 3: Connect both Stage 1 -ve & Stage 2 -ve to Common -ve		Stage 1: Apply Power to Stage 1 +ve & Stage 1 -ve Stage 2: Apply Power to Stage 2 +ve & Stage 2 -ve Stage 3: Apply Power to Stage 3 +ve & Stage 3 -ve Stage 4: Apply Power to Stage 2 +ve & Stage 2 -ve & apply Power to Stage 3 +ve & Stage 3 -ve	

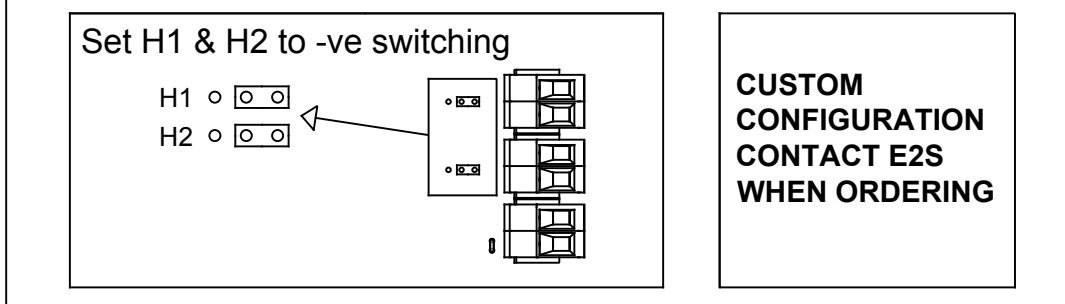
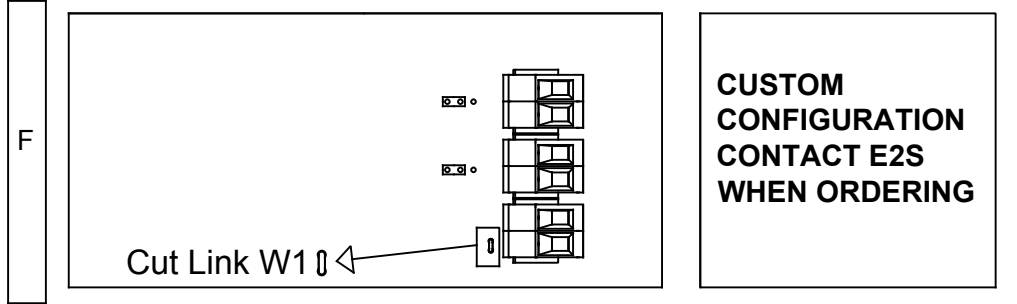
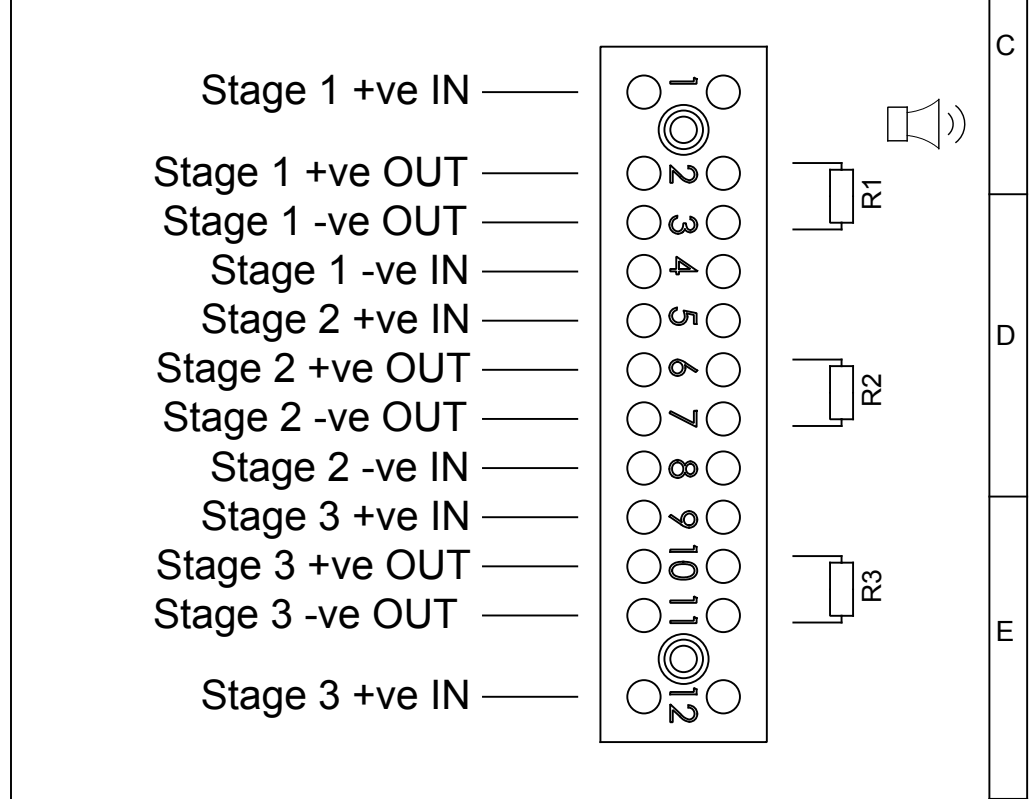
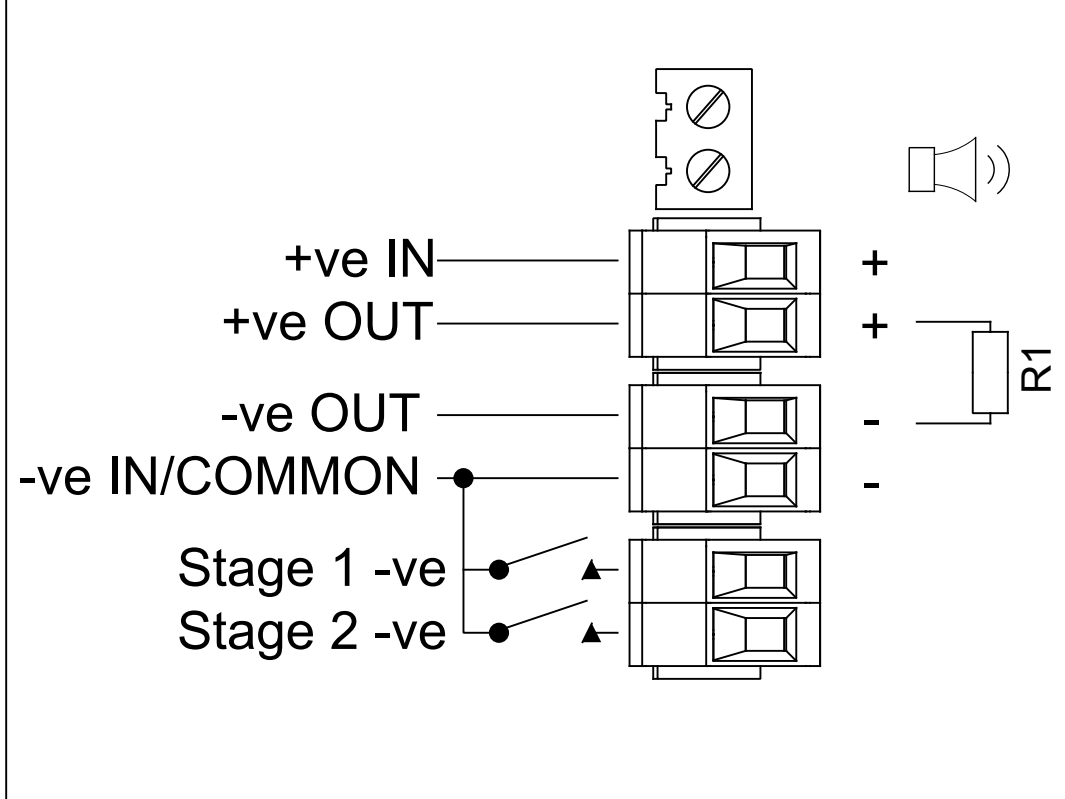
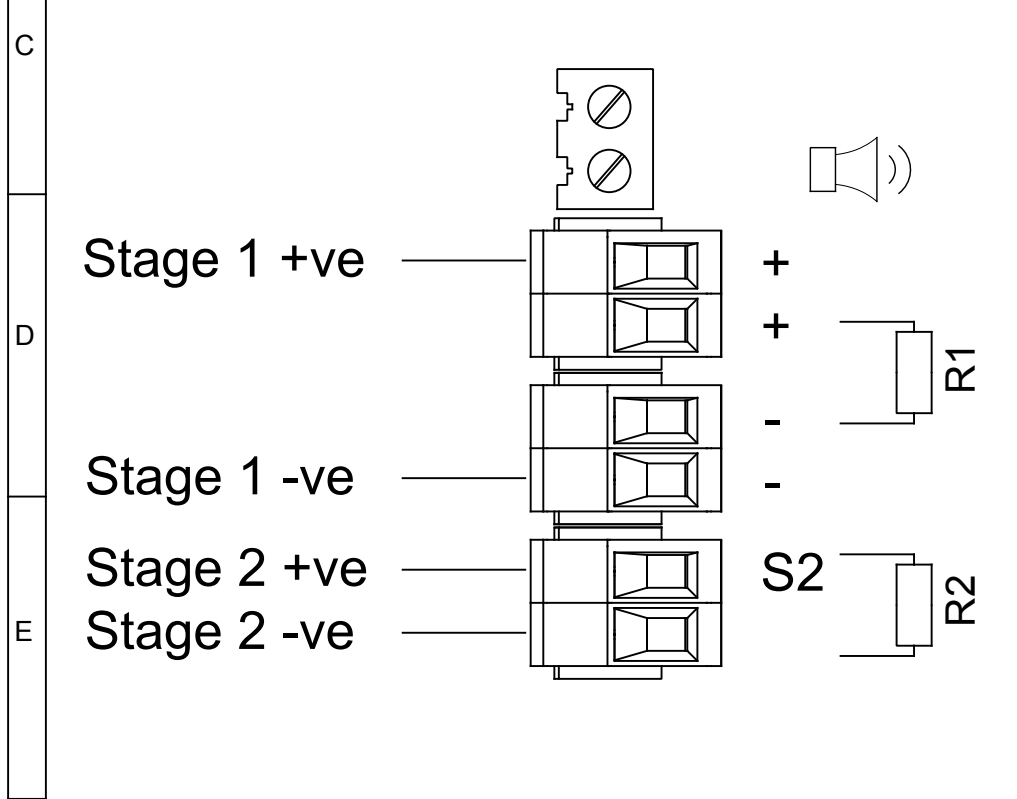

DRAWING TO BS8888:2000 GEOMETRIC TOLERANCES TO ISO1101:1983 LINEAR DIMENSIONAL TOLS ANGULAR DIMENSIONAL TOLS	DRAWN	DATE	SURFACE FINISH	WEIGHT (Kg)	THIS DRAWING AND ANY INFORMATION OR DESCRIPTIVE MATTER THEREIN IS COMMUNICATED IN CONFIDENCE AND IS THE COPYRIGHT PROPERTY OF EUROPEAN SAFETY SYSTEMS LTD. NEITHER THE WHOLE OR ANY EXTRACT MAY BE DISCLOSED, LOANED, COPIED OR USED FOR MANUFACTURING OR TENDERING PURPOSES WITHOUT THEIR WRITTEN CONSENT.	ALL DIMENSIONS IN MM IF IN DOUBT, ASK - DO NOT SCALE		A3
	R.S.RAIT	05/03/2021	MATERIAL					
	CHECKED	DATE	ALTERNATIVE MATERIAL					
	B.ISARD	05/03/2021						
STANDARDS	APPROVED	DATE			EUROPEAN SAFETY SYSTEMS LTD. AS PER LATEST DATE OF ISSUE SHOWN ABOVE	TITLE MA1R, MA1F, MA2F & MA2H DC SOUNDER WIRING DIAGRAMS		
M RANGE	R.N.POTTS	05/03/2021				SCALE	SHEET	DRAWING NUMBER
				NTS		3 OF 3	D207-06-001	



Single Stage Configuration Stage 1: Apply Power to Stage 1 Live & Stage 1 Neutral	Config.: 1a	Three/Four Stage Configuration Stage 1: Apply Power to Live & Neutral Stage 2: Apply Power to Live & Neutral & connect Stage 2 to Common Stage 3: Apply Power to Live & Neutral & connect Stage 3 to Common Stage 4: Apply Power to Live & Neutral & connect both Stage 2 & Stage 3 to Common	Config.: 1b	Two Stage Voltage Free Activation Configuration Power: Live & Neutral Stage 1: Connect Stage 1 to Common Stage 2: Connect Stage 2 to Common Stage 3: Connect both Stage 1 & Stage 2 to Common	Config.: 2
---	-------------	--	-------------	--	------------

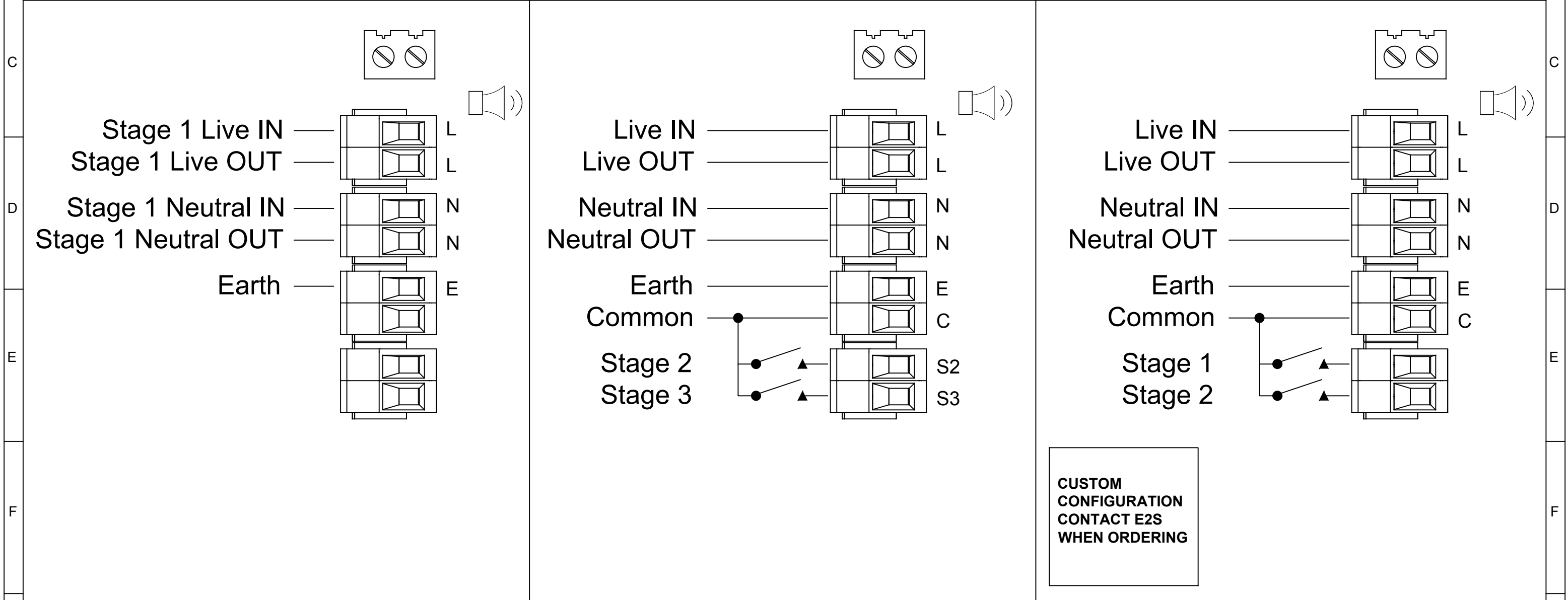

DRAWING TO BS8888:2000 GEOMETRIC TOLERANCES TO ISO1101:1983 LINEAR DIMENSIONAL TOLS ANGULAR DIMENSIONAL TOLS	DRAWN R.S.RAIT	DATE 05/03/2021	SURFACE FINISH	WEIGHT (Kg)	THIS DRAWING AND ANY INFORMATION OR DESCRIPTIVE MATTER THEREIN IS COMMUNICATED IN CONFIDENCE AND IS THE COPYRIGHT PROPERTY OF EUROPEAN SAFETY SYSTEMS LTD. NEITHER THE WHOLE OR ANY EXTRACT MAY BE DISCLOSED, LOANED, COPIED OR USED FOR MANUFACTURING OR TENDERING PURPOSES WITHOUT THEIR WRITTEN CONSENT. © EUROPEAN SAFETY SYSTEMS LTD. AS PER LATEST DATE OF ISSUE SHOWN ABOVE		ALL DIMENSIONS IN MM IF IN DOUBT, ASK - DO NOT SCALE		A3	
STANDARDS M RANGE	CHECKED B.ISARD	DATE 05/03/2021	MATERIAL			TITLE MA1R, MA1F, MA2F, MA2H AC SOUNDER WIRING DIAGRAMS				
	APPROVED R.N.POTTS	DATE 05/03/2021	ALTERNATIVE MATERIAL			SCALE NTS	SHEET 1 OF 1	DRAWING NUMBER D207-06-005		

Stage 1 Set DIP SW 1 Tone No.	Tone Description	Tone Visual	Stage 1 & 2 DIP SW 1/2 Settings 1 2 3 4 5 6	Stage 3 Set DIP SW 1 (S3)	Stage 4 Set DIP SW 1 (S2 + S3)
1	1000Hz PFEER Toxic Gas		000000	2	44
2	1200/500Hz @ 1Hz DIN /PFEER P.T.A.P.		100000	3	44
3	1000Hz @ 0.5Hz (1s on, 1soff) PFEER Gen. Alarm		010000	2	44
4	1.4KHz-1.6KHz 1s, 1.6KHz-1.4KHz 0.5s NF C 48-265		110000	24	1
5	544Hz(100mS)/440Hz (400mS) NF S 32-001		001000	19	1
6	1500/500Hz - (0.5s on, 0.5s off) x3 + 1s gap AS4428		101000	44	1
7	500-1500Hz Sweeping 2 sec on 1 sec off AS4428		011000	44	1
8	500/1200Hz @ 0.26Hz (3.3son, 0.5s off) Netherlands - NEN 2575		111000	24	35
9	1000Hz (1s on, 1s off)x7 + (7s on, 1s off) IMO Code 1a		000100	34	1
10	1000Hz (1s on, 1s off)x7 + (7s on, 1s off) IMO Code 1a		100100	34	1
11	420Hz(0.5s on, 0.5s off)x3 + 1s gap ISO 8201 Temporal Pattern		010100	1	8
12	1000Hz(0.5s on, 0.5s off)x3 + 1s gap ISO 8201 Temporal Pattern		110100	1	8
13	422/775Hz - (0.85 on, 0.5 off) x3 + 1s gap NFPA - Temporal Coded		001100	1	8
14	1000/2000Hz @ 1Hz Singapore		101100	3	35
15	300Hz Continuous (f=300)		011100	24	1
16	440Hz Continuous (f=440)		111100	24	1
17	470Hz Continuous (f=470)		00010	24	8
18	500Hz Continuous IMO code 2 (Low) (f=500)		100010	24	8
19	554Hz Continuous (f=554)		010010	24	8
20	660Hz Continuous (f=660)		110010	24	35
21	800Hz IMO code 2 (High) (f=800)		001010	24	35
22	1200Hz Continuous (f=1200)		101010	24	35
23	2000Hz Continuous (f=2000)		011010	3	35
24	2400Hz Continuous (f=2400)		111010	20	35
25	440Hz @0.83Hz (50 cycles/minute) Intermittent (f=440, a=0.6, b=0.6)		000110	44	8
26	470Hz @0.9Hz - 1.1s Intermittent (f=470, a=0.55, b=0.55)		100110	44	8
27	470Hz @5Hz - (5 cycles/second) Intermittent (f=470, a=0.1, b=0.1)		010110	44	8
28	544Hz @ 1.14Hz - 0.875s Intermittent (f=470, a=0.43, b=0.44)		110110	24	8
29	655Hz @ 0.875Hz Intermittent (f=655, a=0.57, b=0.57)		001110	24	8
30	660Hz @0.28Hz - 1.8sec on, 1.8sec off Intermittent (f=660, a=1.8, b=1.8)		101110	24	8
31	660Hz @3.34Hz - 150mS on, 150mS off Intermittent (f=660, a=0.15, b=0.15)		011110	24	8
32	745Hz @ 1Hz Intermittent (f=745, a=0.5, b=0.5)		111110	24	8
33	800Hz - 0.25sec on, 1 sec off Intermittent (f=800, a=0.25, b=1)		000001	24	8
34	800Hz @ 2Hz IMO code 3.a (High) Intermittent (f=800, a=0.25, b=0.25)		100001	24	19
35	1000Hz @ 1Hz Intermittent (f=1000, a=0.5, b=0.5)		010001	24	19
36	2400Hz @ 1Hz Intermittent (f=2400, a=0.5, b=0.5)		110001	24	19
37	2900Hz @ 5Hz Intermittent (f=2900, a=0.1, b=0.1)		001001	24	19
38	363/518Hz @ 1Hz Alternating (f=363, f1=518, a=0.1)		101001	8	19
39	450/500Hz @ 2Hz Alternating (f=450, f1=500, a=0.25)		011001	8	19
40	554/440Hz @ 1Hz Alternating (f=440, f1=554, a=0.5)		111001	24	19
41	554/440Hz @ 0.625Hz Alternating (f=440, f1=554, a=0.8)		000101	8	19
42	561/760Hz @0.83Hz (50 cycles/minute) Alternating (f=561, f1=760, a=0.6)		100101	8	19
43	780/600Hz @ 0.96Hz Alternating (f=600, f1=780, a=0.52)		010101	8	19
44	800/1000Hz @ 2Hz Alternating (f=800, f1=1000, a=0.25)		110101	24	19
45	970/800Hz @ 2Hz Alternating (f=800, f1=970, a=0.25)		001101	8	19
46	800/1000Hz @ 0.875Hz Alternating (f=800, f1=1000, a=0.57)		101101	24	19
47	2400/2900Hz @ 2Hz Alternating (f=2400, f1=2900, a=0.25)		011101	24	19
48	500/1200Hz @ 0.3Hz Sweeping (f=500, f1=1200, a=3.34)		111101	24	12
49	560/1055Hz @ 0.18Hz Sweeping (f=560, f1=1055, a=5.47)		000011	24	12
50	560/1055Hz @ 3.3Hz Sweeping (f=560, f1=1055, a=0.3)		100011	24	12
51	600/1250Hz @ 0.125Hz Sweeping (f=600, f1=1250, a=8)		010011	24	12
52	660/1200Hz @ 1Hz Sweeping (f=660, f1=1200, a=1)		110011	24	12
53	800/1000Hz @ 1Hz Sweeping (f=800, f1=1000, a=1)		001011	24	12
54	800/1000Hz @ 7Hz Sweeping (f=800, f1=1000, a=0.14)		101011	24	12
55	800/1000Hz @ 50Hz Sweeping (f=800, f1=1000, a=0.02)		011011	24	12
56	2400/2900Hz @ 7Hz Sweeping (f=2400, f1=2900, a=0.14)		111011	24	12
57	2400/2900Hz @ 1Hz Sweeping (f=2400, f1=2900, a=1)		000111	24	12
58	2400/2900Hz @ 50Hz Sweeping (f=2400, f1=2900, a=0.02)		100111	24	12
59	2500/3000Hz @ 2Hz Sweeping (f=2500, f1=3000, a=0.5)		010111	24	12
60	2500/3000Hz @ 7.7Hz Sweeping (f=2500, f1=3000, a=0.13)		110111	24	12
61	800Hz Motor Siren (f=800, a=1.6)		001111	24	12
62	1200Hz Motor Siren (f=1200, a=2)		101111	24	12
63	2400Hz Motor Siren (f=2400, a=1.7)		011111	24	12
64	Simulated Bell		111111	21	12