

### 1) Introduction

The GNExS2 and GNExS1 are flameproof sounders which are certified to meet the requirements of the ATEX directive 94/9/EC and the IECEx scheme. The sounders produce loud warning signals and can be used in hazardous areas where potentially flammable atmospheres may be present. Forty-five different stage alarm sounds can be selected by internal switches to independently set the first stage and second stage, the third and fourth stages are externally changed (see *tone table on Page 4*). The GNExS2 unit produces output levels in the 117dB (A) range and the GNExS1 unit produces output levels in the 110dB (A) range.

The sounders are Group II, EPL (equipment protection level) Gb. Dependant on unit type and ambient temperature the equipment is certified 'Ex d IIC Gb' and as such may be used in Zones 1 and 2 with flammable gases and vapours with apparatus groups IIA, IIB & IIC and temperature Classifications of T1, T2, T3 and T4 dependant on ambient temperature, see marking codes in section 2.

The equipment is also certified 'Ex d IIB Gb' and as such may be used in Zones 1 and 2 with flammable gases and vapours with apparatus groups IIA & IIB and temperature Classifications of T1, T2, T3, T4, T5 and T6 dependant on ambient temperature, see marking codes in section 2.

### 2) Marking

All units have a rating label, which carries the following important information:-

Unit Type No. GNExS2 or GNExS1

Input Voltage:	GNExS1	GNExS2
	10-30Vdc or 48Vdc	10-30Vdc or 48Vdc
	100 - 260Vac/dc	100 - 260Vac

Codes: GNExS1  
 Ex d IIC T4 Gb for Ta -60°C to +50°C  
 Ex d IIC T3 Gb for Ta -60°C to +70°C  
 Ex d IIB T6 Gb for Ta -60°C to +50°C  
 Ex d IIB T5 Gb for Ta -60°C to +65°C  
 Ex d IIB T4 Gb for Ta -60°C to +70°C

Codes: GNExS2  
 Ex d IIC T4 Gb for Ta -60°C to +50°C  
 Ex d IIC T3 Gb for Ta -60°C to +58°C  
 Ex d IIB T6 Gb for Ta -60°C to +50°C  
 Ex d IIB T5 Gb for Ta -60°C to +58°C

Certificate No. SIRA 13ATEX1139X  
 IECEx SIR 13.0029X

Epsilon x:  
 Equipment Group  
 and Category:

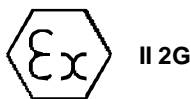

CE Marking:  
 Notified Body No.



### “Warnings”

DO NOT OPEN WHEN AN EXPLOSIVE ATMOSPHERE MAY BE PRESENT

ELECTROSTATIC HAZARD - CLEAN ONLY WITH A DAMP CLOTH

IF TEMPERATURE EXCEEDS 70°C AT ENTRY OR 80°C AT BRANCHING POINT USE SUITABLY RATED CABLE AND CABLE GLANDS

Year of Construction /  
 Serial No. i.e. 13 / 1GS23000001

### 3) Type Approval Standards

The sounders have an EC Type Examination and IECEx certificates issued by KEMA and have been approved to the following standards:-

EN60079-0:2012 IEC60079-0:2011 (Ed6) General Requirements  
 EN60079-1:2007 IEC60079-1:2007 (Ed6) Flameproof Enclosure 'd'

### 4) Installation Requirements

The sounders must be installed in accordance with the latest issues of the relevant parts of the EN 60079 and IEC60079 standards – Selection, Installation and maintenance of electrical apparatus for use in potentially explosive atmospheres (other than mining applications or explosive processing and manufacture):-

EN60079-14:2008 Electrical Installations in Hazardous Areas (other than mines)  
 IEC60079-14:2007 (Ed4)

EN60079-10-1:2009 Classification of Areas, Gas Atmosphere

IEC60079-10:2008 (Ed1)

The installation of the units must also be in accordance with any local codes that may apply and should only be carried out by a competent electrical engineer who has the necessary training.

### 5) Zones, Gas Group, Category and Temperature Classification

The GNExS2 and GNExS1 sounders have been certified Ex d IIC T4 , T3 and Ex d IIB T6 , T5 ,T4 dependant on ambient temperature for full marking see section 2. This means that the units can be installed in locations with the following conditions:-

#### Area Classification:

Zone 1	Explosive gas air mixture likely to occur in normal operation.
Zone 2	Explosive gas air mixture not likely to occur, and if it does, it will only exist for a short time.

#### Gas Groupings:

Group IIA	Propane
Group IIB	Ethylene
Group IIC	Hydrogen and Acetylene

**Equipment Category:** 2G

**Temperature Classification:**

T1	400° C
T2	300° C
T3	200° C
T4	135° C
T5	100° C
T6	85° C

**Ambient Temperature Range:**

GNExS1 - For range see Marking Codes Section 2

GNExS2 - For range see Marking Codes Section 2

## 6) Sounder Location and Mounting

The location of the sounders should be made with due regard to the area over which the warning signal must be audible. The sounders should only be fixed to services that can carry the weight of the unit.

The sounder should be securely bolted to a suitable surface using the 7mm diameter bolt holes in the stainless steel U shaped mounting bracket (see figure 1). The angle can then be adjusted in the direction that the sound is primarily required to cover. This can be achieved by loosening the two large bracket screws in the side of the unit, which allow adjustment in steps of 18°. On completion of the installation the two large bracket adjustment screws on the side of the unit must be fully tightened to ensure that the unit cannot move in service.

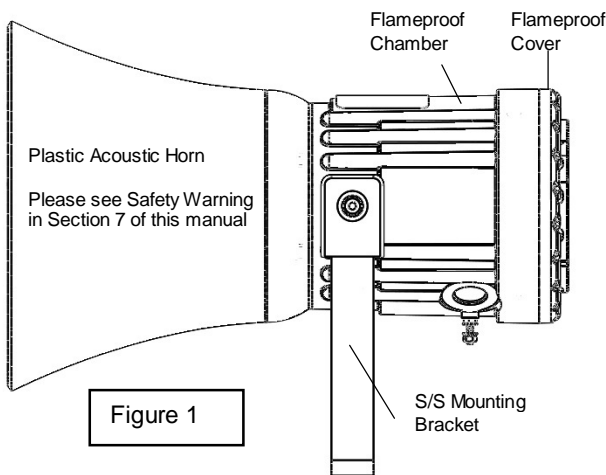

## 7) Safety Warning (Electrostatic Hazard)

The acoustic horn section is made of ABS Plastic, therefore to avoid a possible ELECTROSTATIC CHARGE the unit must only be cleaned with a damp cloth.

## 8) Access to the Flameproof Enclosure

In order to connect the electrical supply cables to the sounder it is necessary to remove the flameproof cover to gain access to the flameproof chamber. To achieve by loosening the M3 Grub Screw within the flameproof cover, and then unscrew the flameproof cover, taking extreme care not to damage the flameproof joints in the process.

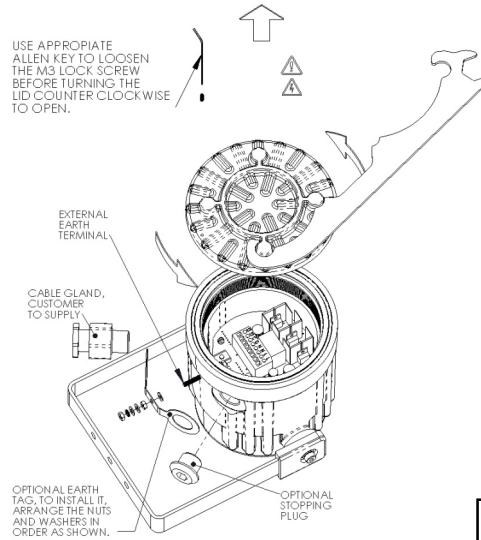

Figure 2

On completion of the cable wiring installation the flameproof joints should be inspected to ensure that they are clean and that they have not been damaged during installation. Also check that the 'O' ring seal is in place. When replacing the flameproof cover ensure that it is tightened fully with tool provided.

## 9) Power Supply Selection

It is important that a suitable power supply is used to run the sounders. The power supply selected must have the necessary capacity to provide the input current to all of the sounders connected to the system.

The following table shows the input current taken by the various sounder units:-

Unit Type	Input Voltage	Input Current	Max. I/P Volts
GNExS2	12V DC	683mA	30V
GNExS2	24V DC	811mA	30V
GNExS2	48V DC	434mA	58V
GNExS2	230V AC	196mA	260V
GNExS2	115V AC	297mA	260V
GNExS1	12V DC	120mA	30V
GNExS1	24V DC	140mA	30V
GNExS1	48V DC	73mA	58V
GNExS1	230V AC	75mA	260V
GNExS1	115V AC	86mA	260V

The input current will vary according to the voltage input level and the frequency of the tone selected. The current levels shown above are for the 440Hz Continuous tone @ nominal input voltage. The above table also shows the maximum voltages at which the sounders can be operated.

## 10) Cable Selection

When selecting the cable size consideration must be given to the input current that each unit draws (see table 2 of 4), the number of sounders on the line and the length of the cable runs. The cable size selected must have the necessary capacity to provide the input current to all of the sounders connected to the line.

**SAFETY WARNING:** If temperature exceeds 70°C at entry or 80°C at branching point use suitably rated cable and cable glands.

### 11) Earthing

Both AC and DC sounder units must be connected to a good quality earth. The units are provided with external earthing terminals which are both located on the terminal chamber section of the unit (see figures 2 and 3).

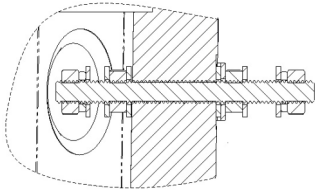

Figure 3

When using the external earth terminal a cable crimp lug must be used. The cable lug should be located between the two M4 stainless steel flat washers. The M4 stainless steel spring washer must be fixed between the outer flat washer and the M4 stainless steel nut to ensure that the cable lug is secured against loosening and twisting.

### 12) Cable Glands

The GNExS2 and GNExS2 sounders have dual cable gland entries which have an M20 x1.5 entry thread as standard. Only cable glands approved for Ex 'd' applications can be used, which must be suitable for the type of cable being used and also meet the requirements of the Ex 'd' flameproof installation standards EN 60079-14:2008 / IEC60079-14:2007.

**SAFETY WARNING:** If temperature exceeds 70°C at entry or 80°C at branching point use suitably rated cable and cable glands.

If a high IP (Ingress Protection) rating is required then a suitable sealing washer must be fitted under the cable gland.

When only one cable entry is used the other one must be closed with an Ex 'd' flameproof blanking plug, which must be suitably approved for the installation requirements.

### 13) Cable Connections

The cable connections are made into the terminal blocks on the electronic PCB assembly located in the flameproof enclosure. See section 8 of this manual for access to the flameproof enclosure.

On the AC units an eight way terminal block is provided for the live (x2), neutral (x2) & earth mains supply wires and also common (C) linking the second (S2) and third (S3) stages, (see figures 5 and 6).

On the DC units a six way terminal block is provided for +ve (x2) and -ve (x2) supply input and second (S2) and third (S3) stage modes of operation, (see figures 4 and 7).

#### GNExS2 DC Sounder

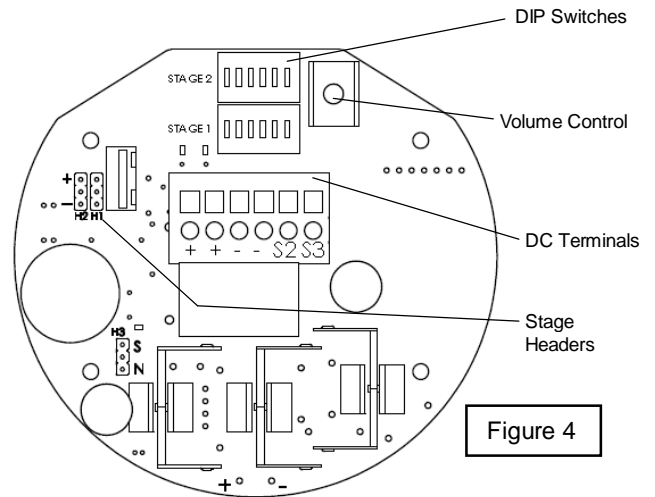

Figure 4

A single wire with a cross sectional area of up to 4mm<sup>2</sup> can be connected to each terminal way or if an input and output wire is required two 2.5mm<sup>2</sup> wires can be connected to each terminal way. When connecting wires to the terminals great care should be taken to dress the wire so that when the cover is inserted into the chamber the wires do not exert excess pressure on the terminal blocks. This is particularly important when using cables with large cross sectional areas such as 2.5mm<sup>2</sup> and above.

#### GNExS2 AC Sounder

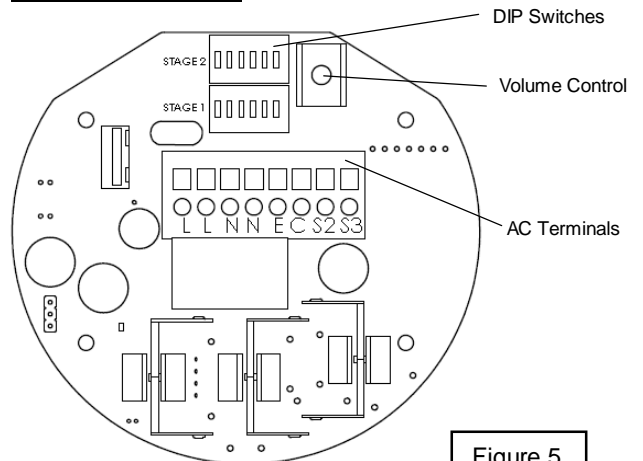

Figure 5

#### GNExS1 AC Sounder

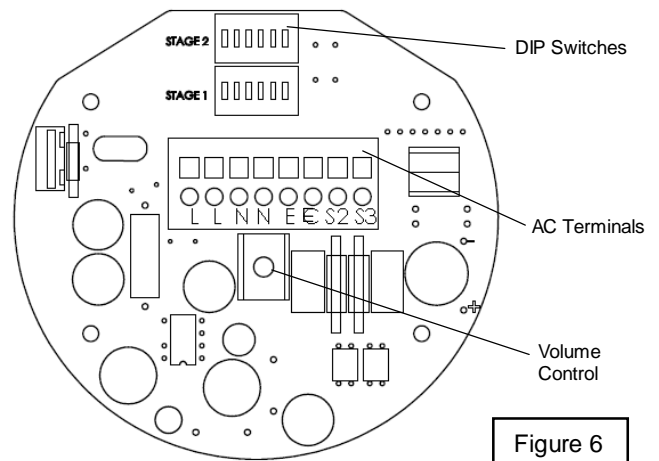
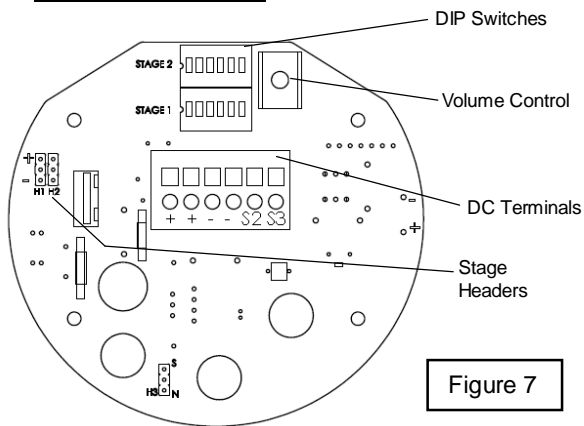

Figure 6

## GNExS1 DC Sounder



### 14) Tone Selection & 1st, 2nd, 3rd & 4th Stage Alarms

The GNExS2 and GNExS1 sounders have 45 different tones that can be selected independently for the first and second stage alarms. The sounders can then be switched to sound the second, third and fourth stage alarm tones. The tones are selected by operation of two DIP switches on the PCB for both DC and AC units. The tone table on page four shows the switch positions for the 45 tones and which tones are available for the third and fourth stages.

Stage one (S1) operation : Simply connect the supply voltage to the normal supply terminals (+ve and -ve for DC units, L and N for AC units). Dip switch 1 alters the stage one tones. The operation of the second, third and fourth stages is different for DC and AC units but the stage one supply terminals must also be connected.

#### DC Units Second, Third and Fourth Stage Tone Selection

The GNExS2 and GNExS1 DC sounders have the facility to use either +ve or -ve switching to change the tone to the second, third and fourth stages. For -ve switching connect the two headers on the pcb to the left-hand (marked -ve) and centre pins. For +ve switching connect the headers to the right hand (marked +ve) and the centre pins.

Stage two (S2) operation : Power +ve and -ve, depending on which switching mode link either a -ve or +ve supply line to the S2 terminal. Dip switch 2 alters stage two tone.

Stage three (S3) operation : Power +ve and -ve, depending on which switching mode link either a -ve or +ve supply line to the S3 terminal. Dip switch 1 alters stage three tone.

Stage four (S4) operation : Power +ve and -ve, depending on which switching mode link either a -ve or +ve supply line to both the S2 & S3 terminals. Dip switch 1 alters stage four tone.

#### GNEx S2 AC Second, Third and Fourth Stage Tone Selection

To select the second, third and fourth stage tones on the GNExS2 AC sounders.

Stage two (S2) operation : Power L and N, link the common (C) and S2 terminal. Dip switch 2 alters stage two tone.

Stage three (S3) operation : Power L and N, link the common (C) and S3 terminals. Dip switch 1 alters stage three tone.

Stage four (S4) operation : Power L and N, link the common (C) both the S2 and S3 terminals. Dip switch 1 alters stage four tone.

#### GNExS1 AC Second, Third and Fourth Stage Tone Selection

To select the second, third and fourth stage tones on the GNExS1 AC sounders.

Stage two (S2) operation : Power L and N, link the L and S2 terminal. Dip switch 2 alters stage two tone.

Stage three (S3) operation : Power L and N, link the L and S3 terminals. Dip switch 1 alters stage three tone.

Stage four (S4) operation : Power L and N, link the L both the S2 and S3 terminals. Dip switch 1 alters stage four tone.

### 15) Volume Control

All GNExS2 and GNExS1 sounders have a volume control to adjust the output level. To set the required output level, adjust the potentiometer on the PCB. For maximum output level the potentiometer should be set to the fully clockwise position.

### 16) End of Line Monitoring (DC Units)

On GNExS2 and GNExS1 DC units, dc reverse line monitoring can be used if required. All DC sounders have a blocking diode fitted in their supply input lines. An end of line monitoring diode or an end of line monitoring resistor can be connected across the +ve and -ve terminals. If an end of line resistor is used it must have a minimum resistance value of 3k3 ohms and a minimum wattage of 0.5 watts or a minimum resistance value of 500 ohms and a min. wattage of 2 watts.

## Wiring Diagram E

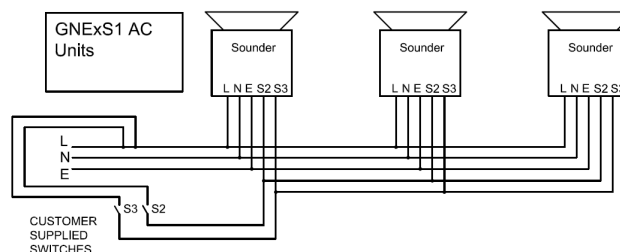
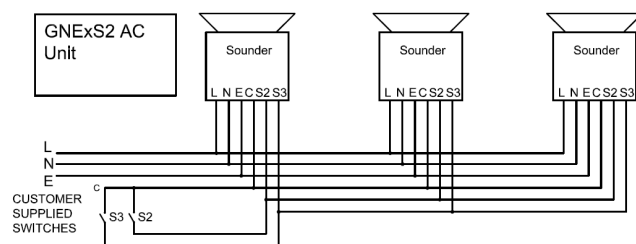
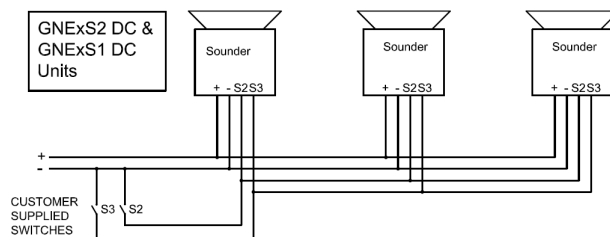

# TONE SELECTION TABLE

## E2S current GNEx 4 stage 45 tone table

Stage 1	Frequency Description		Stage 2						Stage 3	Stage 4	
			Switch 1 & 2		Set DIP	Set DIP	Set DIP	Set DIP			
Switch 1			1	2	3	4	5	6	Switch 1	Switch 1	
			(S2)						(S3)	(S2 + S3)	
Tone 1	340 Hz Continuous								Tone 1	Tone 5	Tone 29
Tone 2	800/1000Hz @ 0.25 sec Alternating								Tone 2	Tone 5	Tone 45
Tone 3	500/1200Hz @ 0.3Hz 0.5 sec Slow Whoop								Tone 3	Tone 5	Tone 29
Tone 4	800/1000Hz @ 1Hz Sweeping								Tone 4	Tone 5	Tone 34
Tone 5	2400Hz Continuous								Tone 5	Tone 20	Tone 29
Tone 6	2400/2900Hz @ 7Hz Sweeping								Tone 6	Tone 5	Tone 45
Tone 7	2400/2900Hz @ 1Hz Sweeping								Tone 7	Tone 5	Tone 45
Tone 8	500/1200/500Hz @ 0.3Hz Sweeping								Tone 8	Tone 5	Tone 45
Tone 9	1200/500Hz @ 1Hz - DIN / PFEER P.T.A.P.								Tone 9	Tone 2	Tone 38
Tone 10	2400/2900Hz @ 2Hz Alternating								Tone 10	Tone 5	Tone 45
Tone 11	1000Hz @ 1Hz Intermittent								Tone 11	Tone 5	Tone 29
Tone 12	800/1000Hz @ 0.875Hz Alternating								Tone 12	Tone 5	Tone 45
Tone 13	2400Hz @ 1Hz Intermittent								Tone 13	Tone 5	Tone 29
Tone 14	800Hz 0.25sec on, 1 sec off Intermittent								Tone 14	Tone 5	Tone 45
Tone 15	800Hz Continuous								Tone 15	Tone 5	Tone 34
Tone 16	660Hz 150mS on, 150mS off Intermittent								Tone 16	Tone 5	Tone 29
Tone 17	544Hz (100mS)/440Hz (400mS) - NF S 32-001								Tone 17	Tone 27	Tone 45
Tone 18	660Hz 1.8sec on, 1.8sec off Intermittent								Tone 18	Tone 5	Tone 45
Tone 19	1.4KHz-1.6KHz 1s, 1.6KHz-1.4KHz 0.5s -NFC48-265								Tone 19	Tone 5	Tone 29
Tone 20	660Hz Continuous								Tone 20	Tone 5	Tone 34
Tone 21	554Hz/440Hz @ 1Hz Alternating								Tone 21	Tone 5	Tone 29
Tone 22	544Hz @ 0.875 sec. Intermittent								Tone 22	Tone 5	Tone 29
Tone 23	800Hz @ 2Hz Intermittent								Tone 23	Tone 5	Tone 29
Tone 24	800/1000Hz @ 50Hz Sweeping								Tone 24	Tone 5	Tone 34
Tone 25	2400/2900Hz @ 50Hz Sweeping								Tone 25	Tone 5	Tone 45
Tone 26	Bell								Tone 26	Tone 15	Tone 34
Tone 27	554Hz Continuous								Tone 27	Tone 5	Tone 29
Tone 28	440Hz Continuous								Tone 28	Tone 5	Tone 45
Tone 29	800/1000Hz @ 7Hz Sweeping								Tone 29	Tone 5	Tone 45
Tone 30	300Hz Continuous								Tone 30	Tone 5	Tone 45
Tone 31	660/1200Hz @ 1Hz Sweeping								Tone 31	Tone 5	Tone 29
Tone 32	Two tone chime.								Tone 32	Tone 15	Tone 45
Tone 33	745Hz @ 1Hz Intermittent								Tone 33	Tone 5	Tone 29
Tone 34	1000 & 2000Hz @ 0.5 sec Alternating - Singapore								Tone 34	Tone 45	Tone 37
Tone 35	420Hz @ 0.625 sec Australian Alert								Tone 35	Tone 5	Tone 34
Tone 36	500-1200Hz 3.75sec /0.25sec. Australian Evac.								Tone 36	Tone 5	Tone 45
Tone 37	1000Hz Continuous - PFEER Toxic Gas								Tone 37	Tone 45	Tone 38
Tone 38	2000Hz Continuous								Tone 38	Tone 45	Tone 37
Tone 39	800Hz 0.25sec on, 1 sec off Intermittent								Tone 39	Tone 17	Tone 37
Tone 40	544Hz (100mS)/440Hz (400mS) - NF S 32-001								Tone 40	Tone 27	Tone 38
Tone 41	Motor Siren - slow rise to 1200 Hz								Tone 41	Tone 5	Tone 29
Tone 42	Motor Siren - slow rise to 800 Hz								Tone 42	Tone 5	Tone 29
Tone 43	1200 Hz Continuous								Tone 43	Tone 5	Tone 45
Tone 44	Motor Siren - slow rise to 2400 Hz								Tone 44	Tone 5	Tone 34
Tone 45	1KHz 1s on, 1s off Intermittent - PFEER Gen. Alarm								Tone 45	Tone 34	Tone 37