

8) Testing unit operation

The tool reset unit can be tested without the need to replace any element.

To test, lift the cover lift flap to reveal the tool reset button. The button should be pressed into the body to activate the unit and place it into the operated condition.

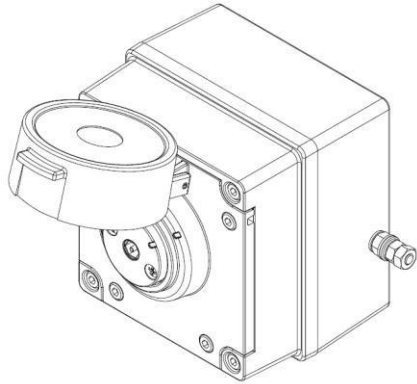

The call point switch will now change over its contacts to operate the alarm. Once testing is complete the unit needs to be reset from the operated condition.

Using the special reset tool provided the tool reset button is rotated anticlockwise by an angle of 55°, see guide alignment marks on button and cover, shown below (1). The tool reset button should pop back up to its original position.

Ensure that the tool reset button has also twisted back clockwise by 55° to its original position see guide marks on button and cover, shown below (2). The unit is now reset.

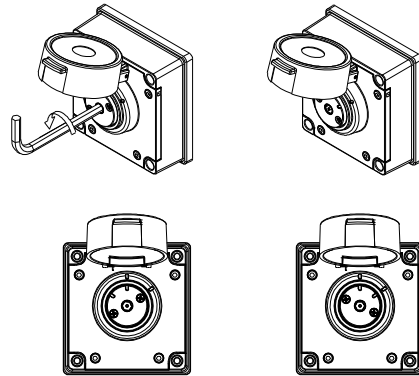

1. On operated unit Twist tool reset button Anticlockwise 55° with special key to reset

2. Button should pop up and twist back to original position

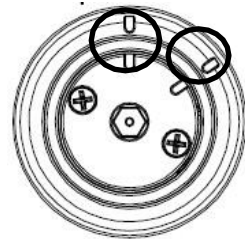

Note: use alignment marks circled to indicate the tool reset buttons status /position.

Unit currently shown as 'standby condition'

Resetting an operated unit is the same as resetting a tested unit.

BExCP3A-PT
Manual Call Point – Tool Reset
For use in Flammable Gas and Combustible Dust Atmospheres

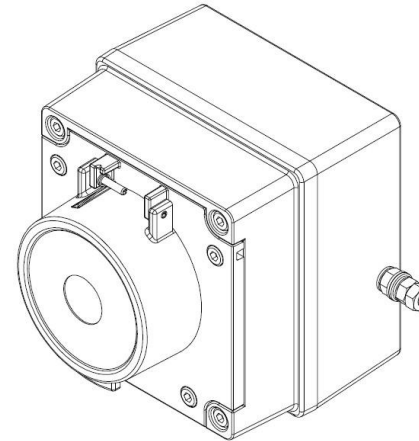

1) Introduction

The BExCP3A-PT is a tool reset manual call point which is certified to the European and International Gas and Dust standards. The unit meets the requirements of the ATEX directive 94/9/EC and IECEx scheme.

The call point can be used in hazardous areas where potentially flammable gas and dust atmospheres may be present.

The BExCP3A-PT has no monitoring resistors. The units are Group II, EPL (equipment protection level) Gb. The equipment is certified 'Ex e d IIC T6 Gb' and as such may be used in Zones 1 and 2 with flammable gases and vapours with gas groups IIA, IIB & IIC and temperature classes T1, T2, T3, T4, T5 and T6.

These units are also Group III, EPL Db. The equipment is certified 'Ex t IIIC T60°C Db' and as such may be used in Zones 21 and 22 for combustible dusts groups IIIA, IIIB & IIIC.

2) Marking

All units have a rating label, which carries the following important information:-

Unit Type No.:
 BExCP3A-PT Manual Call Point

Input Voltage:
 AC voltage 250V Max Current 5.0A Max
 DC voltage 50V Max Current 1.0A Max

Code:
 Ex e d IIC T6 Gb
 Ex t IIIC T60 °C Db
 IP66
 -40°C <= Ta <= +55°C

Certificate No.:
 SIRA 09ATEX3286X
 IECEX SIR 09.0121X

Epsilon x:  II 2GD

CE Marking
 Notified body No.  0518

Year/Serial No. i.e. 09/1CP3APT000001

WARNING - DO NOT OPEN WHEN AN EXPLOSIVE ATMOSPHERE MAY BE PRESENT

3) Type Approval Standards

The beacon has an EC Type examination certificate issued by SIRA and have been approved to the following standards:-

IEC 60079-0:2007
 EN 60079-1:2004 / IEC 60079-1:2003
 EN 60079-7:2007 / IEC 60079-7:2006
 IEC 60079-18:2009

EN 61241-1:2004 / IEC 61241-1:2004

The equipment is certified for use in ambient temperatures in the range -40°C to +55°C and shall not be used outside this range.

4) Installation Requirements

Installation of this equipment shall only be carried out by suitably trained personnel in accordance with the applicable code of practice e.g.

IEC 60079-14/EN 60079-14 and IEC 61241-14/EN 61241-14.

Repair of this equipment shall only be carried out by the manufacturer or in accordance with the applicable code of practice e.g. IEC 60079-19/EN 60079-19.

The certification of this equipment relies on the following materials used in its construction:

Enclosure: Aluminium Pressure Die Cast Body LM6

Through enclosure mechanism: Plastic Nylon Zytel Injection Moulded

Sealing of enclosure and mechanism: O-ring Acrylonitrile-Butadiene Rubber

Potting Compound of resistors where used: Epoxy Resin

If the equipment is likely to come into contact with aggressive substances, then it is the responsibility of the user to take suitable precautions that prevent it from being adversely affected, thus ensuring that the type of protection is not compromised.

"Aggressive substances" - e.g. acidic liquids or gases that may attack metals, or solvents that may affect polymeric materials.

"Suitable precautions" - e.g. regular checks as part of routine inspections or establishing from the material's data sheet that it is resistant to specific chemicals.

Refer to certificates SIRA 09ATEX3286X and IECEX SIR 09.0121X for special conditions of safe use.

5) Call Point Location and Mounting

The location of the call point should enable ease of access for operation and testing. The unit should be mounted using the 4 off fixing holes which will accept up to M4 sized fixings.

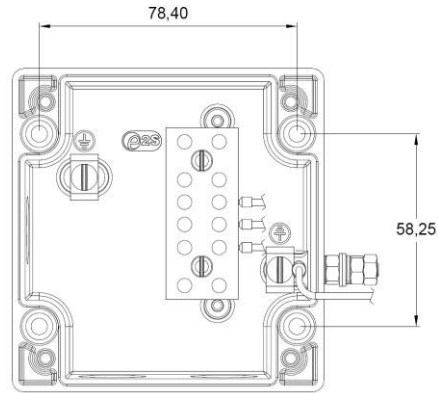

View of base unit showing fixing centres.

To gain access to the mounting holes in the base the front cover must be removed.

This is achieved by removing the 4 off M4 cap head bolts holding on the cover.

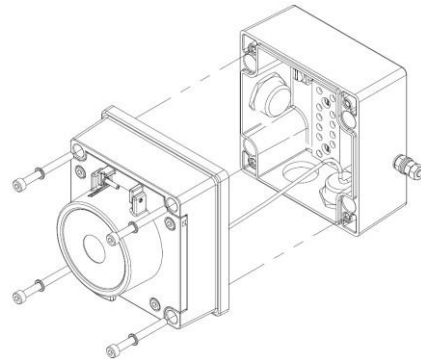

Once the screws are removed the cover will hang down out of the way to gain access to the Ex e terminal block, the internal earth terminal and mounting hole recesses.

6) Earthing

The unit has both internal and external earth terminals. It is recommended that a cable crimp lug is used on the earth wires.

The internal earth wire is placed under a earth clamp which will stop the cable twisting. This is secured by an M4 screw and spring washer.

The external earth lug should be located between the two M5 washers provided and securely locked down with the M5 spring washer and two locknuts.

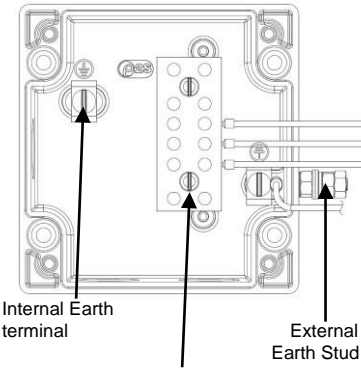

Ex e terminal block

7) Cable connections

There are 3 off cable entries for M20x1.5 Ex e approved cable glands or stopping plugs

The unit can be wired in a number of different ways depending whether normally open or normally closed contacts are required.

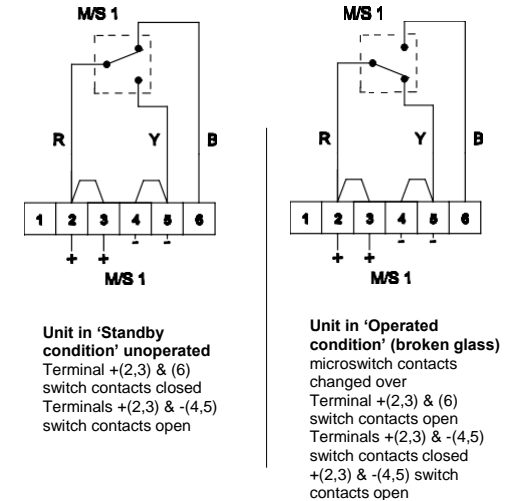

When wiring to Increased Safety terminal enclosures, you are only permitted to connect one wire into each way on the terminal block, unless a pair of wires are crimped into a suitable ferrule.