

1

SPECTRA B350TSB

Traffic Light Beacon
E14 Filament bulb
IP Rating: IP65
Temp: -25°C to +50°C
Unit weight: 210g
CE

Order code Voltage
B350TSB250B/x 12-230V

Multi-unit connection possible using
connector supplied
B450 and B350 units are interconnectable

B350TSB unit is supplied without a bulb
Please order the correct voltage and
wattage

Dimensions : Ø100 x 140mm
1.5mm² terminals
Cable entry: 1 x 5-7mm push through
grommet
2 x M20 cable entry (IP65)

x = L.E.D. colour
R = Red A = Amber
B = Blue C = Clear
G = Green Y = Yellow

Bulbs E14		Version
E2S Part No.		
BR261225E		12V 25W
BR263025E		24V 25W
BR264825E		48V 25W
BR2613025E		115V 25W
BR2623525E		230V 25W

Tel : +44 (0)20 8743 8880 Fax : +44 (0)20 8740 4200
mail : sales@e2s.com web : www.e2s.com



2



ATTENTION: Installation must be carried out by an electrician in compliance with the latest codes and regulations.



ATTENTION: Disconnect from power source before installation or service to prevent electric shock.



ATTENTION: Lens on unit will be hot allow to cool prior to removal.



A SPECTRA B350TSB

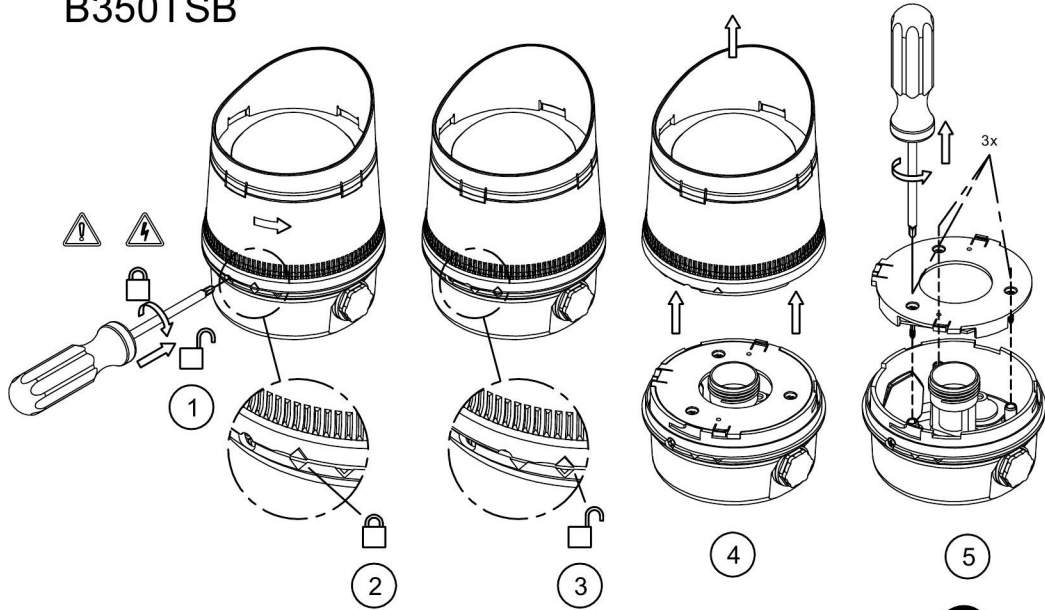

Tel: +44 (0)20 8743 8880 Fax: +44 (0)20 8740 4200
mail: sales@e2s.com web: www.e2s.com

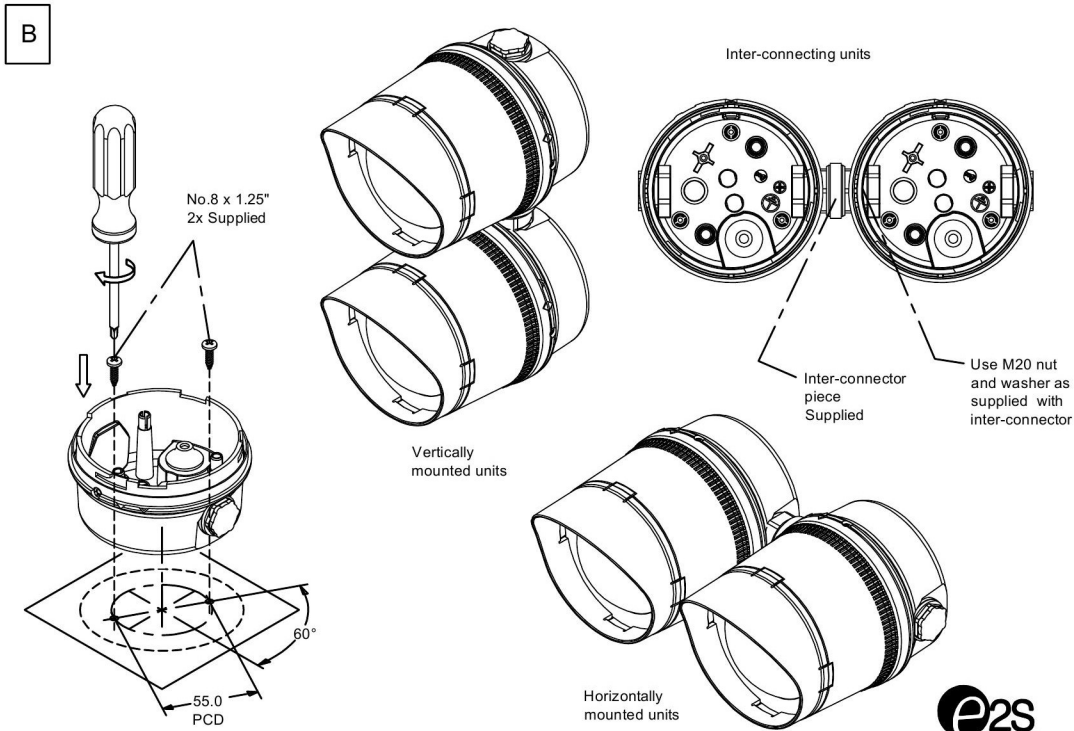
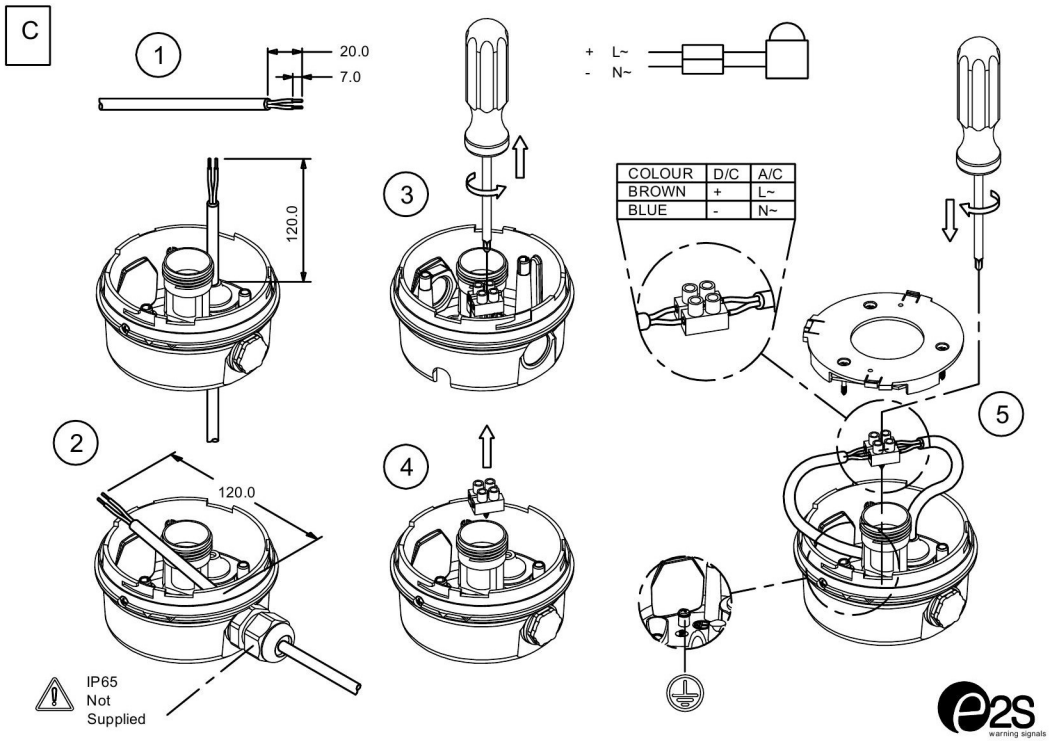

Dimensions in mm

