

ISSUE	MOD No.	REASON - INITIAL - DATE
A		INTRODUCTION OF PART RNP 25-10-07
B		UPDATED TO DUAL DIMS. RSR 24-06-13

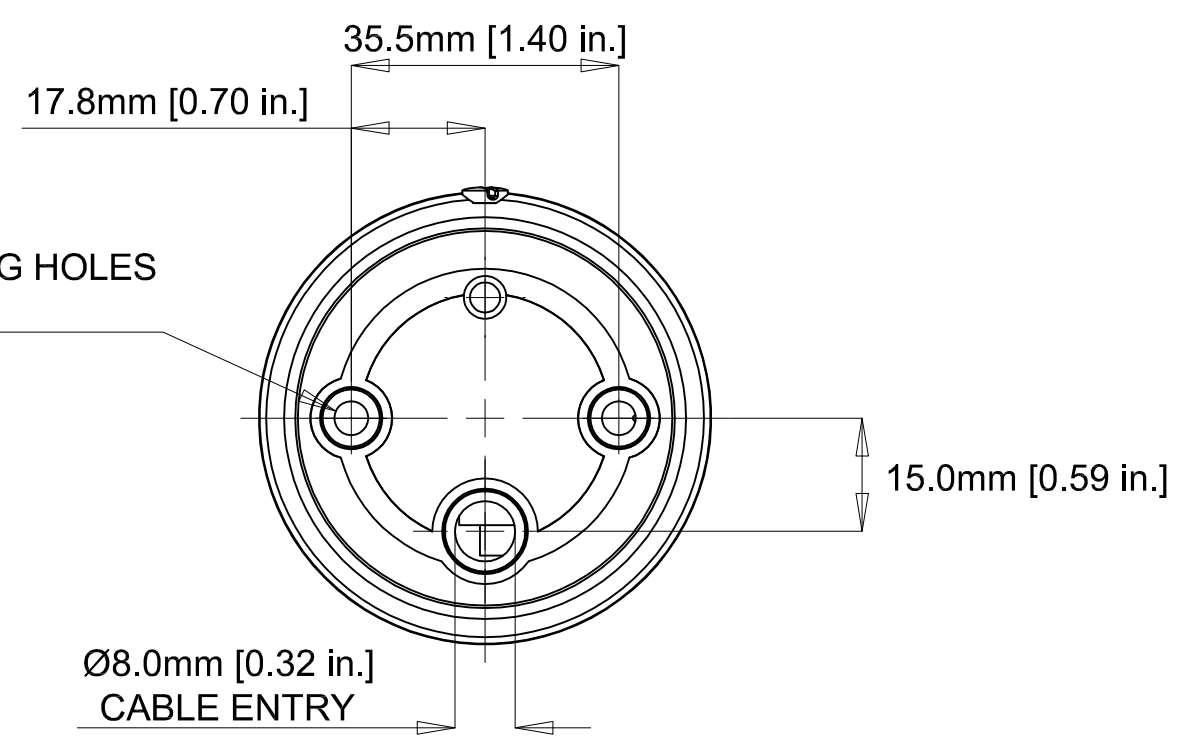
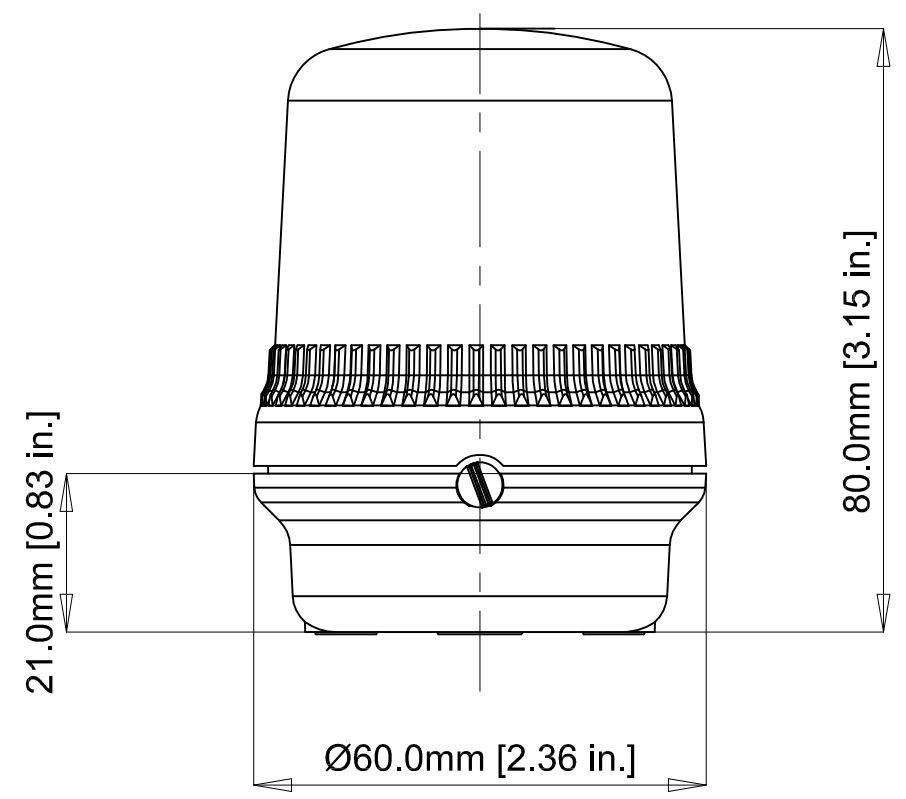

E2S PART NO.	DESCRIPTION	DATA REFERENCE
B200STR...	B200STR PANEL MOUNT XENON STROBE BEACON	2.13.050
B200LDA...	B200LDA PANEL MOUNT LED PERMANENT BEACON	2.14.050
B200SLF...	B200SLF PANEL MOUNT STATUS BEACON (FILAMENT LAMP)	2.15.110
B200FLF...	B200FLF PANEL MOUNT BLINKING BEACON (FILAMENT LAMP)	2.15.120

WHERE APPLICABLE 'UL' VERSIONS ARE COVERED BY THIS OUTLINE DRAWING.

DRAWING TO BS8888:2000
 GEOMETRIC TOLERANCES TO ISO1101:1983
 LINEAR DIMENSIONAL TOLS
 ANGULAR DIMENSIONAL TOLS

STANDARDS
 SPECTRA

DRAWN R.N.POTTS	DATE 25.10.07
CHECKED	DATE
APPROVED	DATE

SURFACE FINISH FINISH	WEIGHT (Kg)
MATERIAL	
ALTERNATIVE MATERIAL	

THIS DRAWING AND ANY INFORMATION OR DESCRIPTIVE MATTER THEREIN IS COMMUNICATED IN CONFIDENCE AND IS THE COPYRIGHT PROPERTY OF EUROPEAN SAFETY SYSTEMS LTD. NEITHER THE WHOLE OR ANY EXTRACT MAY BE DISCLOSED, LOANED, COPIED OR USED FOR MANUFACTURING OR TENDERING PURPOSES WITHOUT THEIR WRITTEN CONSENT.

EUROPEAN SAFETY SYSTEMS LTD.
 AS PER LATEST DATE OF ISSUE SHOWN ABOVE

EUROPEAN SAFETY SYSTEMS LTD
 IMPRESS HOUSE
 MANSELL ROAD
 ACTON
 LONDON W3 7QH
 WWW.E2S.COM

ALL DIMENSIONS IN MM & [in.] IF IN DOUBT, ASK - DO NOT SCALE				A2
TITLE B200 INSTALLATION OUTLINE SIZE				
SCALE 1:1	SHEET 1 OF 1	DRAWING NUMBER SK0010		