

ISSUE	MOD No.	REASON - INITIAL - DATE
A		INTRODUCTION OF PART RNP 25-10-07
B		UPDATED TO DUAL DIMS. RSR 24-06-13

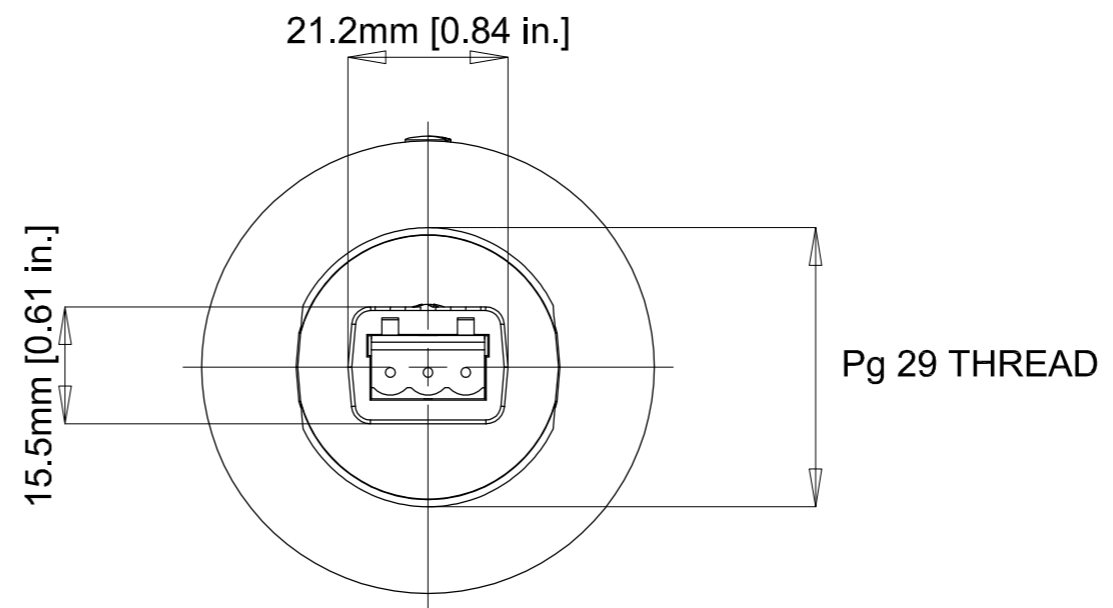
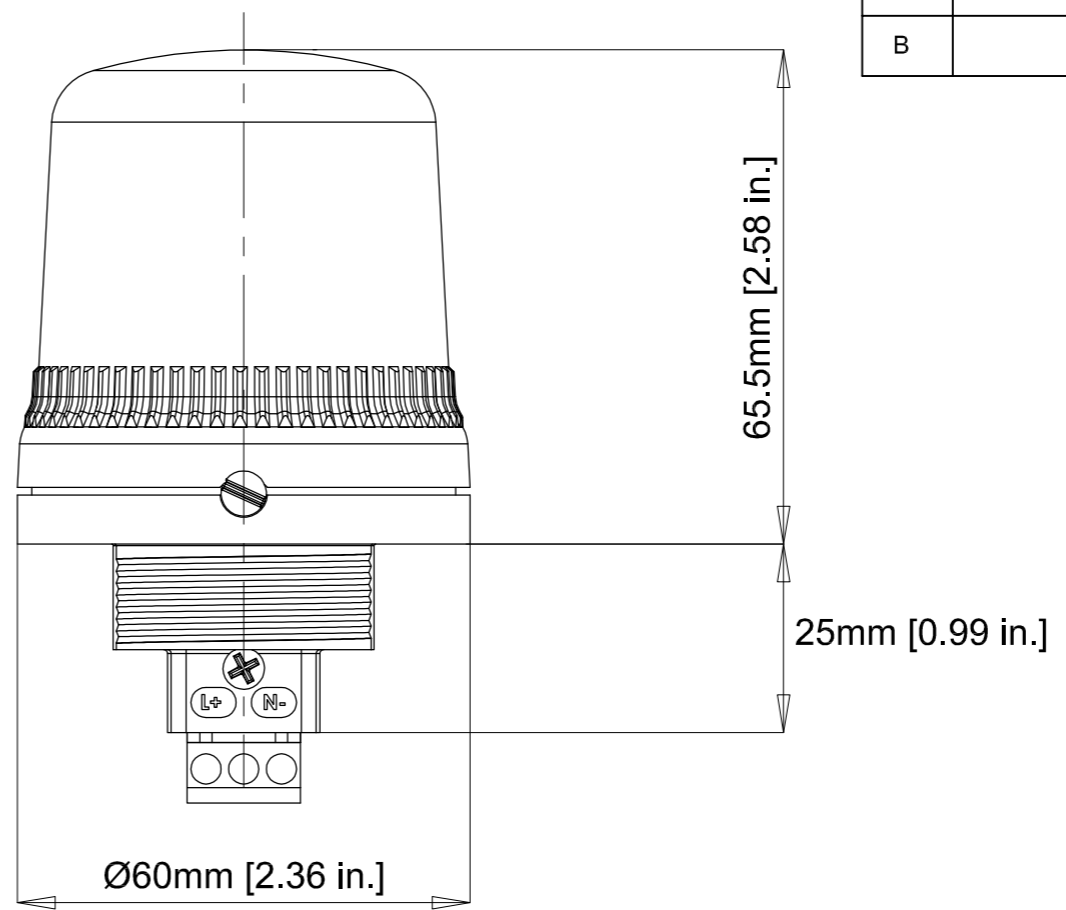

E2S PART NO.	DESCRIPTION	DATA REFERENCE
B100STR...	B100STR PANEL MOUNT XENON STROBE BEACON	2.13.040
B100LDA...	B100LDA PANEL MOUNT LED PERMANENT BEACON	2.14.040
B100SLF...	B100SLF PANEL MOUNT STATUS BEACON (FILAMENT LAMP)	2.15.090
B100FLF...	B100FLF PANEL MOUNT BLINKING BEACON (FILAMENT LAMP)	2.15.100

WHERE APPLICABLE '-UL' VERSIONS ARE COVERED BY THIS OUTLINE DRAWING.

DRAWING TO BS8888:2000 GEOMETRIC TOLERANCES TO ISO1101:1983 LINEAR DIMENSIONAL TOLS ANGULAR DIMENSIONAL TOLS	DRAWN R.N.POTTS	DATE 25.10.07	SURFACE FINISH FINISH	WEIGHT (Kg)	THIS DRAWING AND ANY INFORMATION OR DESCRIPTIVE MATTER THEREIN IS COMMUNICATED IN CONFIDENCE AND IS THE COPYRIGHT PROPERTY OF EUROPEAN SAFETY SYSTEMS LTD. NEITHER THE WHOLE OR ANY EXTRACT MAY BE DISCLOSED, LOANED, COPIED OR USED FOR MANUFACTURING OR TENDERING PURPOSES WITHOUT THEIR WRITTEN CONSENT. EUROPEAN SAFETY SYSTEMS LTD. AS PER LATEST DATE OF ISSUE SHOWN ABOVE	EUROPEAN SAFETY SYSTEMS LTD IMPRESS HOUSE MANSELL ROAD ACTON LONDON W3 7QH WWW.E2S.COM	ALL DIMENSIONS IN MM & [in.] IF IN DOUBT, ASK - DO NOT SCALE		A3
	CHECKED	DATE	MATERIAL				TITLE B100 INSTALLATION OUTLINE SIZE		
	APPROVED	DATE	ALTERNATIVE MATERIAL				SCALE 1:1	SHEET 1 OF 1	DRAWING NUMBER SK0009